

Rev.	CN No.	Description	Revised By	Reviewed By	Approved By	Approved Date
B	NA	Added Length and Weight for Bend Restrictor	BJZE	ANOH	ANOH	2023-03-15
A	NA	First issue	BJZE	ANOH	ANOH	2022-12-15

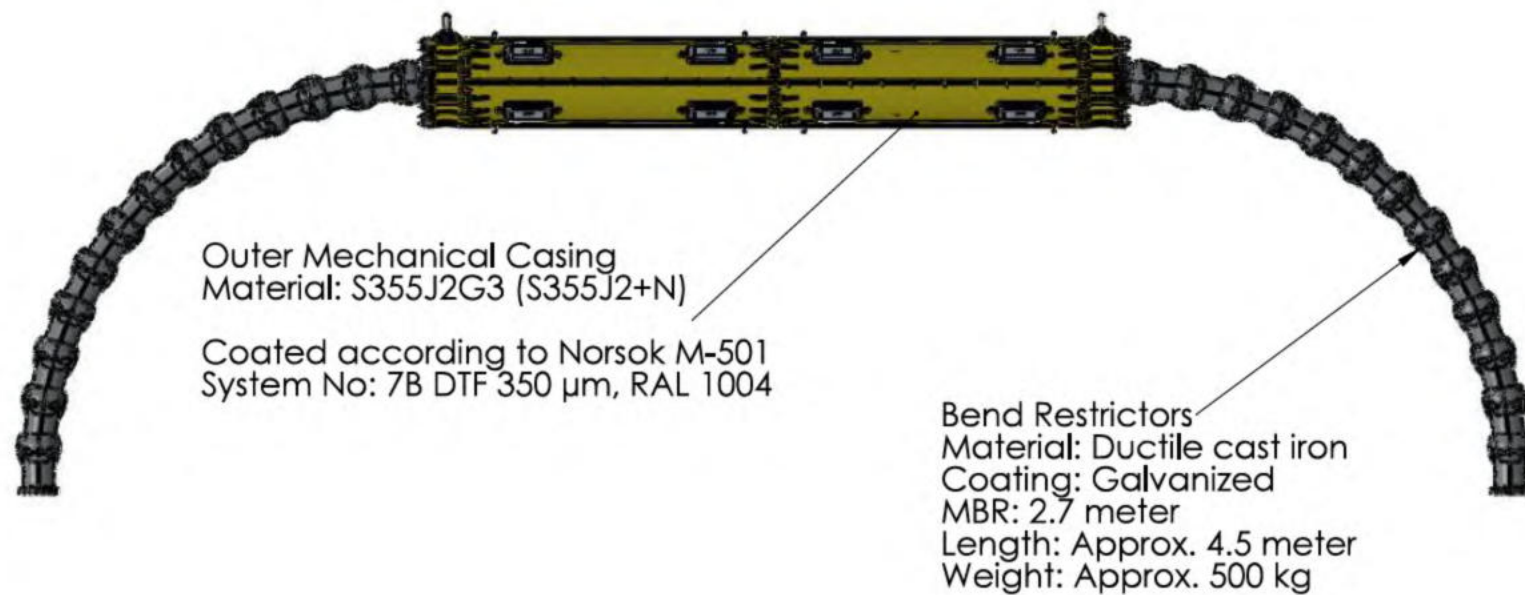

Data/ Technical specification

Weight joint excl. cable outside rigid part
Weight in air 2,7 T
Weight in water 2,0 T

Weight joint excl. cable outside rigid part and Bend Restrictors
Weight in air 1,7 T
Weight in water 1,2 T

Overall Dimensions
Outer diameter 0,62 m
Length Rigid section 4,85 m
Length incl. Bend Restrictors 13,8m

Anodes
Total mass approx 86,4 kg
Bolted to joint hull
Calculated cathodic protection to the joint for 40 years design life

12 ton shackle, 2 pcs per joint. For lifting and handling of complete joint.

Distance Flange
the distance flange house the armour attachment, supports the lifting lug and connects the Bend restrictor to the OMC

Coated according to Norsok M-501
System No: 7B DTF 350 µm, RAL 1004

Aluminium anodes
The total mass of anodes needed on the outside and inside of the Outer Mechanical Casing is calculated separately according to DNV-RP-B401

Stainless steel Inner Watertight Casing
Plumb sealed to the lead sheath. Covered with a corrosion protective sheath consisting of an inner layer of butyl rubber and an outer sheath of XLPE.
The IWC metallically seals the premoulded cable joint from NKT, JDC 525 kV DC.

Soldering Cone
Supports the plum solder and acts as a size transition between the IWC and the cable metallic sheath

Weld flange
Cable armour attachment flange, the armour is attached to the flange by welding and flange is bolted to the OMC

We reserve all rights in this document and in the information contained therein. Reproduction, use or disclosure to third parties without express authority is strictly forbidden. © NKT HV Cables AB.

	RSJ JDC525				Scale 1:50	View	Sheet Size A3
	General arrangement drawing				State Approved		Rel. Phase Code
					General Tolerance SS-ISO 2768-mK SS-EN-ISO 13920-BF		
	Drawn By BJZE	Reviewed By ANOH	Approved By ANOH	Approved Date 2022-12-15	Sheet No. 1/1	Drawing No. 1GG0080565	Rev. B



APPENDIX F. THERMAL & AMPACITY STUDY

[12 Pages]



CHPE LLC

HVDC LAKE CHAMPLAIN CROSSINGS

**Thermal Impact on Crossed Utility
Infrastructure – Protective Duct (Uraguard)**



CHPE LLC

Thermal Impact on Crossed Utility Infrastructure – Protective Duct (Uraguard)

TYPE OF DOCUMENT (VERSION) PUBLIC

PROJECT NO. 70082351

OUR REF. NO. 70082351-TN-018

DATE: JULY 2023

WSP

2 London Square

Cross Lanes

Guildford, Surrey

GU1 1UN

Phone: +44 148 352 8400

WSP.com



QUALITY CONTROL

Issue/revision	First Issue
Remarks	Original
Date	19/07/2023
Prepared by	Joe Stubbs
Signature	Stubbs, Joseph (UKJJS012) <small>Digitally signed by Stubbs, Joseph (UKJJS012) DN: cn=Stubbs, Joseph (UKJJS012), o=Active, email=Joseph.Stubbs@wsp.com Reason: I am the author of this document Date: 2023.07.20 15:48:51 +0100</small>
Checked by	Marc Rosales
Signature	Rosales, Marc (UKMJR009) <small>Digitally signed by Rosales, Marc (UKMJR009) DN: cn=Rosales, Marc (UKMJR009), o=Active, email=marc.rosales@wsp.com Reason: I am the checker of this document Date: 2023.07.20 15:54:37 +0100</small>
Authorised by	Dan Evans
Signature	 <small>Digitally signed by Evans, Dan (UKDLE002) DN: cn=Evans, Dan (UKDLE002), o=Active, email=Daniel.Evans@wsp.com Date: 2023.07.20 15:51:03 +0100</small>
Project number	70082351
Report number	70082351-TN-018
File reference	70082351-TN-018



CONTENTS

	EXECUTIVE SUMMARY	2
	REFERENCED DOCUMENTS	3
1	INTRODUCTION	4
2	CABLE AND INSTALLATION DETAILS	5
2.1	CABLE DESIGN AND LOADING	5
2.2	CROSSING ARRANGEMENTS	5
3	MODELLING	6
3.1	GENERAL	6
3.2	ASSUMPTIONS	6
3.3	VALIDATION	6
3.4	RESULTS	7
4	DISCUSSION AND CONCLUSIONS	9



EXECUTIVE SUMMARY

The Champlain Hudson Power Express (CHPE) high voltage direct current (HVDC) submarine cables will cross utility assets at various points along its route. CHPE requested that WSP establishes the expected temperature rise of utility assets due to the HVDC submarine cables at Lake Champlain crossing locations where alternate (non-burial) means of cable protection are required.

WSP has carried out thermal modelling to determine an indicative temperature rise of the lake bed beneath the HVDC submarine cables when considering the proposed crossing installation arrangements. This report relates to deep water crossings where the HVDC cables are installed within a protective duct.

The proposed crossing arrangement is unlikely to significantly restrict convection in its 'as-laid' form, as free water should be able to flow around both the protective duct and utility asset. Over time, however, there may be a build-up of lakebed material around the assets at the crossing location and this would present a more onerous thermal environment for both assets.

A model has been prepared to approximate the installation arrangement at the crossing location. The model and assumptions used are intended to represent a worst-case scenario and hence, where no other heat sources are present, the temperatures presented can be considered as maximum values.

The maximum temperature rise beneath the HVDC submarine cables due to heat being dissipated by the cables has been found to be approximately 5 K (9 °F).

For utility assets which do not themselves generate heat, this can be considered as the maximum temperature rise of the asset. If there is no build up in lakebed material around the assets, the temperature rise would be reduced.

Where the utility asset being crossed is a heat source, such as a power cable, the maximum temperature rise due to the HVDC cables of 5 K (9 °F) will result in a slight de-rating of the asset at the crossing location.

The ampacity of a power cable is defined by the thermal pinch point along its length. If elsewhere the asset is buried deeper in the lake bed, or installed in another more onerous environment (e.g. within a horizontal directional drilled (HDD) section), then the crossing location is unlikely to represent a thermal pinch-point and would not impact the ampacity of the cable.



REFERENCED DOCUMENTS

Author	Document Number	Document Title
NKT	1AA0557110	Datasheet – Submarine Cable
NKT	1AA0529714	Design Report Submarine Cable



1 INTRODUCTION

The CHPE HVDC submarine cables will cross third party utility assets at various points along its route. CHPE requested that WSP establishes the expected temperature rise of these unburied utility assets due to the HVDC submarine cables at Lake Champlain crossing locations, where alternate (non-burial) means of cable protection are required.

WSP has carried out thermal modelling to determine an indicative temperature rise of the lake bed beneath the HVDC submarine cables when considering the proposed crossing installation arrangements. This report covers an arrangement for deep water depths of more than 150 feet (ft), where a protective duct (e.g. Uraguard) solution will be employed.

This report details the modelling that has been carried out and presents the results.



2 CABLE AND INSTALLATION DETAILS

2.1 CABLE DESIGN AND LOADING

The design of the HVDC submarine cable is detailed in NKT document '1AA0557110'.

As per NKT document '1AA0529714' each cable will carry a maximum continuous load of 1638 Amps (A).

2.2 CROSSING ARRANGEMENTS

The method of alternate (non-burial) cable protection to be employed is subject to the local water depth.

For water depths greater than 150 ft, the HVDC submarine cables will be brought to the surface of the lake bed and enclosed in a protective duct (e.g. Uranguard), Figure 2-1, as they cross the existing asset. The HVDC bundle will be laid directly on top of the existing asset.

Figure 2-1 - Indicative cable bundle with Uranguard protection

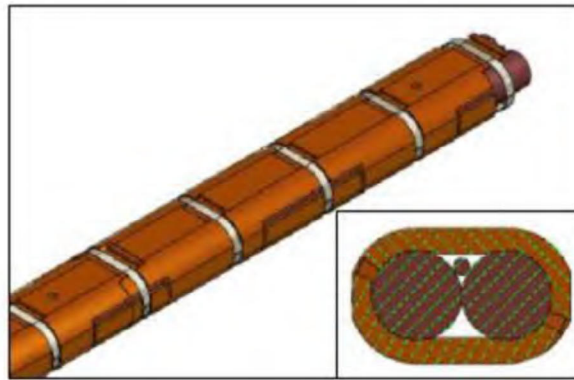

CHPE - CABLE BUNDLE W/URAGUARD PROTECTION (or SIMILAR)

SCALE: N.T.S.



3 MODELLING

3.1 GENERAL

Modelling has been conducted using the CYMCAP v 8.2 software package to out to determine the temperature rise beneath the HVDC submarine cables for the installation described in Section 2.

The installation arrangement has been approximated using the multiple backfill module in CYMCAP.

Due to limitations of the modelling software (2D only), each backfill segment has been modelled with infinite length in the z-direction. The protective duct arrangement has been modelled with the cables having a surround of lake bed material, as opposed to being on top of the lake bed (and the crossed asset). This is intended to represent a scenario where lake bed movement has resulted in material being deposited around the assets, and represents a worst case in terms of the heat dissipation capability of the cables.

The model layout used is shown in Figure 3-1, with water shown in blue.

Figure 3-1 – Model layout for protective duct scenario

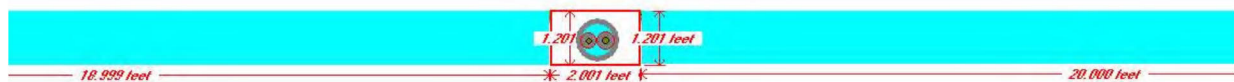

3.2 ASSUMPTIONS

The following assumptions have been made:

- HVDC cables carrying their maximum continuous load of 1638 A.
- Lake bed thermal resistivity is 1.54 Kelvin metres per Watt (K.m/W) (worst case in NKT document '1AA0529714');
- A range of ambient temperatures between 40 and 70 °F have been considered. In a lake environment, ambient temperature will vary with depth and season. The effect of seasons becomes minor at water depths beyond approximately 30 feet. It is therefore expected that values toward the lower end of this range will be applicable for crossing location.
- Protective duct wall (polyurethane) thermal resistivity is 3.50 K.m/W;
- Region between protective duct and cable is water filled;
- Boundary of water and lake bed surface is isothermal;
- Losses due to harmonic content are negligible;
- No longitudinal heat transfer.

3.3 VALIDATION

In order to confirm that the cable model had been established correctly, a comparison was made with a scenario presented in the NKT design report. Good agreement between the model and report confirmed the validity of the model.



3.4 RESULTS

An isothermal plot of the temperature rise around the HVDC submarine cables, where they are installed within a protective duct surrounded by lakebed material, is shown in Figure 3-2. **Reference source not found.**

The 1 °C isotherm provides an indication of the boundary, outside of which the thermal influence of the HVDC cables will be negligible.

Immediately beneath the mattress protection, the ambient temperature is increased by approximately 5 °C (9 °F). This would be the maximum temperature rise that a crossed asset might experience. The impact of this temperature rise on a range of ambient temperatures is outlined in Table 3-1.

Table 3-1 – Impact of temperature rise at crossing due to HVDC cables

Ambient temperature, °F	Temperature rise, °F	New temperature, °F
40	9	49
50	9	59
60	9	69
70	9	79



Figure 3-2 - Plot of temperature rise isotherms with protective duct

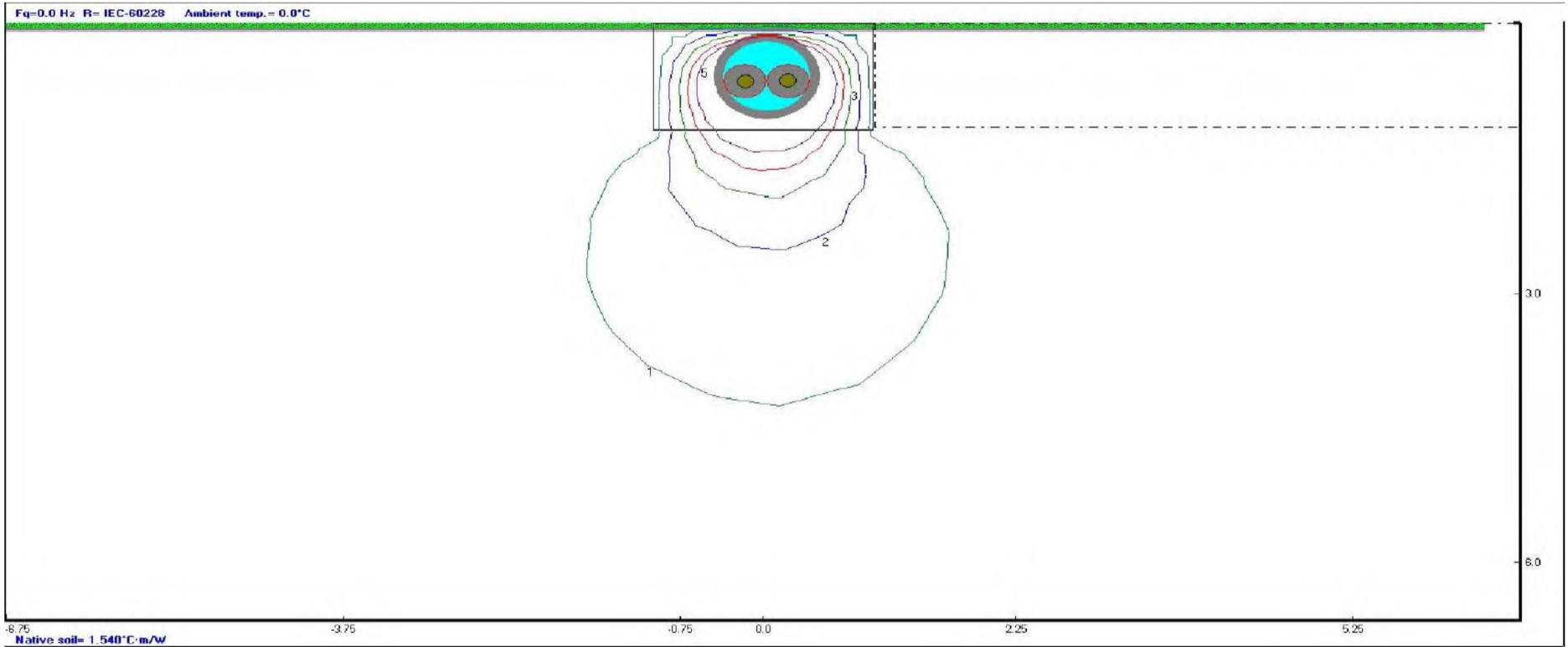

Note: temperatures in °C; distances in ft.



4 DISCUSSION AND CONCLUSIONS

The proposed crossing arrangement is unlikely to significantly restrict convection in its 'as-laid' form, as free water should be able to flow around both the protective duct and utility asset. Over time, however, there may be a build-up of lakebed material around the assets at the crossing location and this would present a more onerous thermal environment for both assets.

A model has been prepared to approximate the installation arrangement at the crossing location. The model and assumptions used are intended to represent a worst-case scenario and hence, where no other heat sources are present, the temperatures presented can be considered as maximum values.

The maximum temperature rise beneath the HVDC submarine cables due to heat being dissipated by the cables has been found to be approximately 5 K (9 °F).

For utility assets which do not themselves generate heat, this can be considered as the maximum temperature rise of the asset. If there is no build up in lakebed material around the assets, the temperature rise would be reduced.

Where the utility asset being crossed is a heat source, such as a power cable, the maximum temperature rise due to the HVDC cables of 5 K (9 °F) will result in a slight de-rating of the asset at the crossing location.

The ampacity of a power cable is defined by the thermal pinch point along its length. If elsewhere the asset is buried deeper in the lake bed, or installed in another more onerous environment (e.g. within a horizontal directional drilled (HDD) section), then the crossing location is unlikely to represent a thermal pinch-point and would not impact the ampacity of the cable.



APPENDIX G. ELECTRICAL EFFECTS STUDY

[15 Pages]



CHPE LLC

SUBMARINE DC CABLES

**Potential Effects of Submarine DC Cables on
Co-Located Infrastructure**



CHPE LLC

Potential Effects of Submarine DC Cables on Co-Located Infrastructure

TYPE OF DOCUMENT (VERSION) CONFIDENTIAL

PROJECT NO. 70082351

OUR REF. NO. 70082351-TN-015

DATE: JULY 2023

WSP

2 London Square

Cross Lanes

Guildford, Surrey

GU1 1UN

Phone: +44 148 352 8400

WSP.com



QUALITY CONTROL

Issue/revision	First Issue
Remarks	Original
Date	14/07/2023
Prepared by	Marc Rosales
Signature	Rosales, Marc (UKMJR009) <small> Digitally signed by Rosales, Marc (UKMJR009) DN: cn=Rosales, Marc (UKMJR009), ou=Active, email=marc.rosales@wsp.com Reason: I am the author of this document Date: 2023.07.14 14:00:13 +0100 </small>
Checked by	Joe Stubbs
Signature	Stubbs, Joseph (UKJJS012) <small> Digitally signed by Stubbs, Joseph (UKJJS012) DN: cn=Stubbs, Joseph (UKJJS012), ou=Active, email=Joseph.Stubbs@wsp.com Reason: I have reviewed the document Date: 2023.07.14 15:26:25 +0100 </small>
Authorised by	Dan Evans
Signature	 <small> Digitally signed by Evans, Dan (UKDLE002) DN: cn=Evans, Dan (UKDLE002), ou=Active, email=Daniel.Evans@wsp.com Date: 2023.07.14 16:37:12 +0100 </small>
Project number	70082351
Report number	70082351-TN-015
File reference	70082351-TN-015



CONTENTS

1	INTRODUCTION AND EXECUTIVE SUMMARY	2
2	REFERENCED DOCUMENTS	3
3	HVDC TRANSMISSION OVERVIEW	4
3.1	HVDC TECHNOLOGY	4
3.2	HVDC TOPOLOGY	4
4	DC CABLE EFFECTS ON CO-LOCATED INFRASTRUCTURE	6
4.1	GENERAL	6
4.2	ELECTRIC FIELDS	6
4.3	MAGNETIC FIELDS	6
4.4	INDUCED VOLTAGE	7
	4.4.1. GENERAL	7
	4.4.2. CALCULATION METHODOLOGY AND ASSUMPTIONS	8
	4.4.3. DISCUSSION	9
4.5	CORROSION EFFECTS	10
4.6	TRANSIENT FAULT CONDITIONS	11
4.7	THERMAL EFFECTS	12



1 INTRODUCTION AND EXECUTIVE SUMMARY

1.1 INTRODUCTION

The Champlain Hudson Power Express (CHPE) project will deliver 1250MW of renewable power from Hydro-Quebec TransEnergie's Hertel substation near La Prairie Quebec to NYPA's Astoria Annex 345kV substation located in the Astoria neighbourhood in the New York City borough of Queens.

A high voltage direct current (HVDC) transmission system will be used to achieve this. The HVDC transmission system will comprise a single AC to DC converter at each end of the link connected by two DC cables, one positive and one negative.

The HVDC cable route within the United States will comprise approximately 193 miles of submarine cable route and approximately 147 miles of land cable route.

The proposed submarine HVDC cable route will enter and exit Lake Champlain through horizontal directionally drilled (HDD) ducts. In water depths less than 150 feet (mean water level) the two cables are to be laid together in a trench at approximately 4 feet below the lake bottom. In water depths greater than 150 feet, the cables are to be laid directly on the lake bottom, without burial or protection, and are expected to settle 1 foot below the lake bottom.

At various points of the underwater route there are assets and infrastructure co-located in the same right of way (ROW).

CHPE has asked WSP to carry out an assessment of the potential effects of the HVDC cables on co-located infrastructure.

This report details the assessment that has been carried out and presents the findings. It should be noted that any future modification of the design may impact this assessment.

1.2 EXECUTIVE SUMMARY

The topology and design of the CHPE interconnector, and the associated configuration of the submarine DC cables, have been taken into account when assessing the potential interference effects on co-located utility assets. The effects that have been considered are:

- Electric fields
- Magnetic fields
- Induced voltages
- Corrosion effects
- Transient fault conditions

Indicative studies have been carried out and these studies indicate that the proposed HVDC cable system will have no adverse effect on any co-located utility assets or infrastructure, with regard to electric and magnetic fields, induced voltages, corrosion and transient fault conditions.

Thermal effects at crossing locations have been considered separately to this report.



2 REFERENCED DOCUMENTS

Document Number	Document Title
1AA0557110	Datasheet – Submarine Cable
1AA0529714	Design Report Submarine Cable
IEC 60287-1-1	Electric cables- Calculation of current rating – Part 1: Current rating equations (100% load factor) and calculation of losses
CIGRE TB 283	Special Bonding of High Voltage Power Cables
ISO 18086:2019	Corrosion of metals and alloys – Determination of AC corrosion – Protection criteria



3 HVDC TRANSMISSION OVERVIEW

3.1 HVDC TECHNOLOGY

The CHPE Interconnector will use the latest HVDC technology, known as Voltage Source Converter (VSC). This has now become the dominant technology used for HVDC interconnectors as it provides additional functionality when compared with the earlier generation of Line Commutated Converters (LCC).

The VSC is designed as a Modular Multi-level Converter (MMC) in which the DC capacitor, which maintains the DC voltage, is segmented into many small units each of which is switched in and out by a semi-conductor switching device. The voltage on each DC capacitor is about 2 kV. By progressively switching in and out steps of DC voltage in the correct sequence a stepped voltage waveform can be generated which, with many hundreds of steps, becomes a good approximation to an AC sinusoidal waveform. The quality of this voltage waveform may be sufficient that AC side harmonic filters are not required.

On the DC side of the converter, the “ripple” voltage generated by the switching action, i.e. AC harmonic distortion, which is superimposed on the DC voltage will induce voltages in adjacent metallic assets and infrastructure and has the potential for interference with telecommunication systems. The spectrum of harmonic currents flowing in the DC cable loop that are the source of any interference issues is from 100 Hz to 5000 Hz.

The design of the modern VSC scheme used by CHPE inherently requires no, or only very small, harmonic filters at the AC terminal to achieve compliance with the standards for acceptable distortion levels in the AC transmission network (in comparison to LCC technology and earlier generations of VSC schemes, which required larger harmonic filters). Similarly, no harmonic filters are normally required at the DC terminal to avoid interference to adjacent telecommunication circuits from the HVDC cable circuit.

3.2 HVDC TOPOLOGY

The chosen circuit topology for CHPE HVDC interconnector is a Symmetrical Monopole.

This topology consists of a single AC to DC converter at each end of the link connected by 2 DC cables, one positive and one negative. A simplified diagram of the symmetrical monopole topology is shown in Figure 3-1.

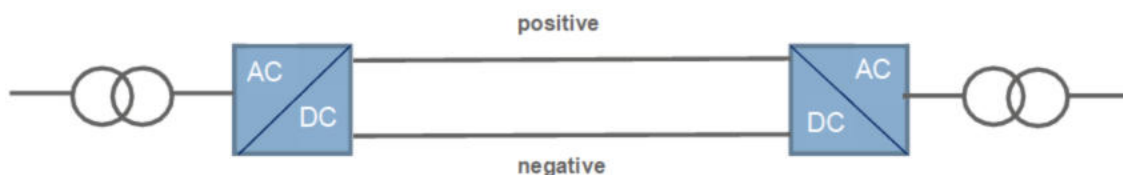

Figure 3-1 – Symmetrical monopole topology

The DC current in the submarine and underground cables flows in the loop between the positive and negative cables and between the two converter stations. In operation there is no path for DC current outside of this loop, thus there can be no DC current flowing in the water or the ground.



In the event of a fault on the AC or DC systems of the interconnector, automatic protection systems will disconnect the complete scheme by opening circuit breakers at the Grid connection points in less than 0.1 seconds. A fault in a submarine (or land) cable would occur between the central high voltage core and the outer sheath, which is connected to ground potential.



4 DC CABLE EFFECTS ON CO-LOCATED INFRASTRUCTURE

4.1 GENERAL

In the following sections the possible effects of the following interactions between DC cable and co-located infrastructure are discussed:

- Electric fields
- Magnetic fields
- Induced voltages
- Corrosion effects
- Transient fault conditions

Where appropriate, indicative studies have been carried out to determine the influence of the CHPE interconnector on susceptible co-located assets. The topology and design of the CHPE interconnector, as well as the associated configuration of the submarine DC cables, have been taken into account for these studies.

It should be noted that a detailed study requires detailed design of the DC cable system to determine the harmonic distortion generated at the DC terminals of the converter stations and a detailed model of the submarine and underground cables. Both models will only be available after the suppliers selected to construct the converter stations and DC cable system have completed detailed designs.

Thermal effects at crossing locations have been considered separately to this report.

4.2 ELECTRIC FIELDS

The electric field of the CHPE DC cables will be fully contained by their earthed metallic sheaths. As such, there will be no electric field external to the cables.

4.3 MAGNETIC FIELDS

The DC cables will generate a magnetic field. This magnetic field will be composed of two types of field: -

- a static field associated with the DC current in the cable conductor
- a field that varies over time as the AC current in the cable conductor varies with time.

The AC current is the result of unwanted “ripple currents” due to the converter not perfectly converting AC current to DC current, and they are significantly less than the DC current. However, the cable sheath will be earthed at both ends of the cable route and any AC current in the conductor will induce a current in the opposite direction in the cable sheath, thereby reducing the overall magnetic field of the cable.

The static field associated with the DC current will interact with the earth’s magnetic field causing a localised increase or decrease in field strength which will decay rapidly as the distance from the centre line of the cable increases. For context, the geomagnetic field varies throughout the Earth from 25 to 65 μ T. In the New York area, the Earth’s magnetic field is approximately 50 μ T.



A preliminary calculation of the potential magnetic field generated by the DC cables is given below:

1. Static Field

The DC current of 1638A flowing in the DC cables will generate a static magnetic field of approximately $36\mu\text{T}$ directly above the trench, 3' above ground level. This field strength decreases rapidly with distance away from the cables, at 10' from the centre of the trench the field is approximately $13\mu\text{T}$ and at 20' the field is approximately $5\mu\text{T}$. These figures can be compared to the earth's natural magnetic field, which is in the region of $50\mu\text{T}$ at the latitude of New York. The stray magnetic field may add (e.g. $63\mu\text{T}$ at 10' distance) or subtract from (e.g. $37\mu\text{T}$ at 10' distance) the natural background field. These are very small changes in the DC magnetic field environment

Static magnetic fields of this magnitude will have no effect on any asset or infrastructure, whether metallic or otherwise.

2. Time Varying Field

The time varying field strength is a function of the superimposed AC harmonic currents, or "ripple", present on the cable system due to the conversion effects from AC to DC. This "ripple" is approximately 1-2% of the DC system current, giving a magnitude in the order of 30 A.

The field strength is also impacted by:

1. The induced sheath current, known as circulating current. This flows in the opposite direction to the current in the cable's conductor and acts to reduce the overall magnitude of the magnetic field. The overall effect is equivalent to the conductor current minus the sheath current. The amount of circulating current will depend on the electrical resistance of the sheath (lower resistance gives higher circulating current) and spacing of cables (greater spacing gives higher circulating currents).
2. The spacing between the conductors, as the current in each cable is in opposite directions so will tend to cancel each other out. Lower cable separation will result in a higher degree of cancellation and lower magnetic fields.

4.4 INDUCED VOLTAGE

4.4.1. General

The time-varying interaction of a cable's magnetic field with a parallel metallic asset (e.g. a pipeline) can result in a voltage being induced on the asset. If the asset is earthed or connected in a loop, the induced voltage will act to drive a circulating current. Such induced voltages and currents can cause safety, interference, damage, and corrosion concerns.

The magnitude of induced voltage is influenced by the magnetic field strength (as discussed in Section 4.3), its rate of change, the separation of the cable and asset, and the length of parallelism.

As per Faraday's Law of Induction, where an asset is perpendicular to the cable there will be no induced voltage as only the parallel component of a magnetic field contributes to this phenomenon. When assessing the possibility of an interaction it is generally considered that where an asset runs



at an angle of greater than 45° to a cable, the interaction can be neglected, as any inductive effect would be negligible. For crossing angles of less than 45°, the assets are modelled as being parallel, as a worst case.

The major component of the current in the cables is DC, which generates a static magnetic field and will not induce a voltage on co-located utility assets. Hence, the only concern relates to the time varying magnetic field resulting from AC harmonic currents. The actual magnitude and frequency of these harmonic currents will not be known until detailed design of the converter system has been completed. At this stage, they are expected to have a magnitude of approximately 1-2 % of the DC system current, in the order of 30 A.

All identified assets that cross the HVDC cables do so at angles greater than 45° meaning the interactions would be negligible, as described above. Despite this, an indicative study has been conducted to demonstrate the level of induced voltage that could be expected on a metallic asset that ran parallel to the DC cables.

4.4.2. Calculation methodology and assumptions

The levels of voltage that could be induced on parallel assets by the DC cables have been calculated using established formulae. Details of the formulae, parameters and assumptions used are given below.

The induced voltage is derived from the following series of formulae:

The reactance per unit length of sheath

$$X = 2\omega 10^{-7} \ln\left(\frac{2s}{d}\right) \quad \Omega/\text{m} \quad (\text{see IEC 60287-1-1 Section 2.3.1})$$

Where:

- ω = angular frequency ($2\pi f$) (1/s)
- S = axial spacing between cables (mm)
- d = mean diameter of sheath (mm)

The current in the sheath induced by the current in the conductor

$$I_s = \frac{I}{\sqrt{1 + \left(\frac{R_s}{X}\right)^2}} \quad \text{A} \quad (\text{see IEC 60287-1-1 Section 2.3.1})$$

Where:

- I = current in conductor (A)
- R_s = the sheath resistance (Ω)

The reactance per unit length between the DC cables (cable m and cable n) and the parallel conductor (p) per unit length

$$X_{mnp} = 2\omega 10^{-7} \ln\left(\frac{d_{mp}}{d_{np}}\right) \quad \Omega/\text{m} \quad (\text{derived from CIGRE TB 283 equation A6})$$

Where:

- d_{mp} = distance between DC cable m and parallel conductor p
- d_{np} = distance between DC cable n and parallel conductor p

Induced voltage on parallel conductor per unit length is



$$V = (I - I_s)X_{mnp}L \quad V$$

Where:

L = length of parallelism

The following inputs were assumed:

Harmonic current (I) - 2% of rated current, 32.76A, selected as the upper limit of the expected value.

Frequency (f) – 60Hz

Cable spacing (S) – 5.43" (0.138 m) – selected to represent the distance between the cable conductors as the cables would be touching in the trench.

Cable dimensions and resistances (d, R_s) – selected from NKT design information provided in document 1AA0529714 Rev A or calculated by the methods of IEC 60287-1-1 Section 2.4.3.

Spacing to asset (d_{mp} , d_{np}) – An indicative horizontal separation of 5' has been assumed between the nearest cable and parallel asset.

Length of parallelism (L) – An indicative length of 1640' (500m) was assumed.

Notes;-

- Calculations are based on the fundamental frequency (60Hz), rather than a spectrum of smaller components at different frequencies. As mentioned previously this report gives an approximation of the induced voltages to be expected. Detailed studies only being possible after the completion of the converter and cable systems detailed designs by the contractors. In this case, as the level of induced voltage is so low, further studies are considered unnecessary.
- As noted previously, where the angle between cables and utility assets is 90° there will theoretically be no induced voltage.

4.4.3. Discussion

All identified assets that cross the HVDC cables do so at angles greater than 45° meaning that any induced voltage would be negligible. Despite this, an indicative study has been conducted to demonstrate the level of induced voltage that could be expected on a metallic asset that ran parallel to the DC cables.

The induced voltage on the indicative parallel asset was calculated to be 0.0739V, or approximately 0.1478mV/m. This is the maximum voltage that would be present at one end of the parallel section. This level of induced voltage is considerably below typical limits but has also been considered in more detail from a corrosion perspective in the following section.

If the parallel asset is non-metallic, there will be no induced voltage.

It should be noted that the calculated induced voltage values represent a worst-case figure, present at one end of the parallel section. Depending on the phase relationship, this voltage may act to add or subtract from any existing voltage on an asset. Furthermore, if the asset has any discontinuity, or regular earthing, the induced voltage in one section will not transfer across the discontinuity into the next section. This would result in lower induced voltage values.



4.5 CORROSION EFFECTS

The risk of corrosion of buried metallic utility assets is related to the effects of stray DC currents and induced AC voltages.

For CHPE, the chosen HVDC topology is symmetrical monopole. The DC current in the submarine and underground cables flow in the loop through the positive and negative cables between the two converter stations. There is no path for a DC current outside of this loop under normal operating conditions. During faults, current will return via the path of least resistance which will be predominantly through the cable metallic layers. Any stray DC current return via the mass of earth is expected to be negligible, due to its relatively very high resistance. Due to the negligible DC current and short duration, this would not result in any corrosion concerns.

As discussed in Section 4.4, an AC voltage will be induced on parallel metallic assets (e.g. a pipeline) as a result of the AC component of current carried by the DC cable system. For coated metallic pipelines, where the asset has a defect in its coating, the AC voltage can act to drive a current to earth. If the AC voltage is large enough, this can potentially cause corrosion.

In this case all the identified assets are running perpendicular and so there will theoretically be no induced voltage. There will consequently be no AC corrosion concerns as a result of the HVDC cables.

In order to provide an indication of the effect the HVDC cables have on an asset that did run parallel, an indicative assessment has been carried out below.

For the indicative assessment, an AC induced voltage of 0.0739 V has been assumed as discussed in section 4.4. To assess whether this would cause corrosion concerns, the guidance in ISO 18086:2019 has been applied. ISO 18086:2019 suggests two conditions should be met to avoid AC corrosion. Firstly, the AC voltage should be 15 V rms or lower. Secondly, the AC average current density should be lower than 30 A/m² on a 1 cm² coupon.

The first condition is met in this case, with a maximum induced voltage of < 0.1 V.

To assess the second condition, the AC current density must be considered, which is a function of the induced voltage, local soil resistivity and the size of coating defect.

The representative AC current density is given by:

$$J_{AC} = \frac{8 V_{AC}}{\rho \pi d} \quad \Omega/m$$

Where:

- J_{AC} = AC current density (Am⁻²)
- V_{AC} = AC voltage (V)
- ρ = Soil resistivity (Ω.m)
- d = Defect diameter (m)

With regard to soil resistivity, ISO 18086 provides an indication of the risk of AC corrosion associated with different values of soil resistivity, Table 4-1. The actual soil resistivity along the route is currently unknown and hence a range of values have been considered.

**Table 4-1 – AC corrosion risk for soil resistivity (ISO 18086)**

Soil resistivity ($\Omega.m$)	AC corrosion risk
< 25	Very high
25 to 100	High
100 to 300	Medium
> 300	Low

The calculated AC current density values for a range of soil resistivities are presented in Table 4-2.

Table 4-2 – AC current density for different soil resistivities

Soil resistivity, ($\Omega.m$)	AC current density (Am^{-2})
25	0.7
50	0.3
75	0.2
100	0.2

As mentioned in section 4.4 all interactions with co-located assets are perpendicular meaning there would theoretically be no induced voltage and consequently no AC corrosion concern.

An indicative assessment for a parallel asset has shown that even if an asset were to run parallel, the induced voltage and corrosion risk would be minimal.

4.6 TRANSIENT FAULT CONDITIONS

A fault on the system will result in a short-term disturbance to the steady state (normal) system voltage and current.

In the event of a fault, the current in the DC cable system will rise by a factor of approximately 10 for a period of time of around 100 ms, which is the time taken for the main circuit breakers to open and isolate the fault.

During this short time the magnetic fields and induced voltage resulting from the DC cable system will rise to a level proportional to the increase in current due to the fault.

Under fault conditions the level of induced voltage on parallel assets may be expected to increase to a maximum of approximately 0.739 V. This is below typical limits and would not present any safety concern.



4.7 THERMAL EFFECTS

Thermal effects at crossing locations have been considered separately to this report.



CHAMPLAIN HUDSON POWER EXPRESS
CROSSING ARRANGEMENT – LC-20, LC-20A & LC-20B

[END OF DOCUMENT]



CHAMPLAIN HUDSON POWER EXPRESS

CROSSING ARRANGEMENT - LAKE CHAMPLAIN

Unknown CI Owner

CHPE Crossing Reference LC-22

Area:	Lake Champlain – between Port Douglass, NY and Burlington, VT		
CHPE Crossing Reference	Crossing Location		Crossing Description
	Northing	Easting	
LC-22	██████████	██████████	Identified by S.T. Hudson Q2 2023 Survey.

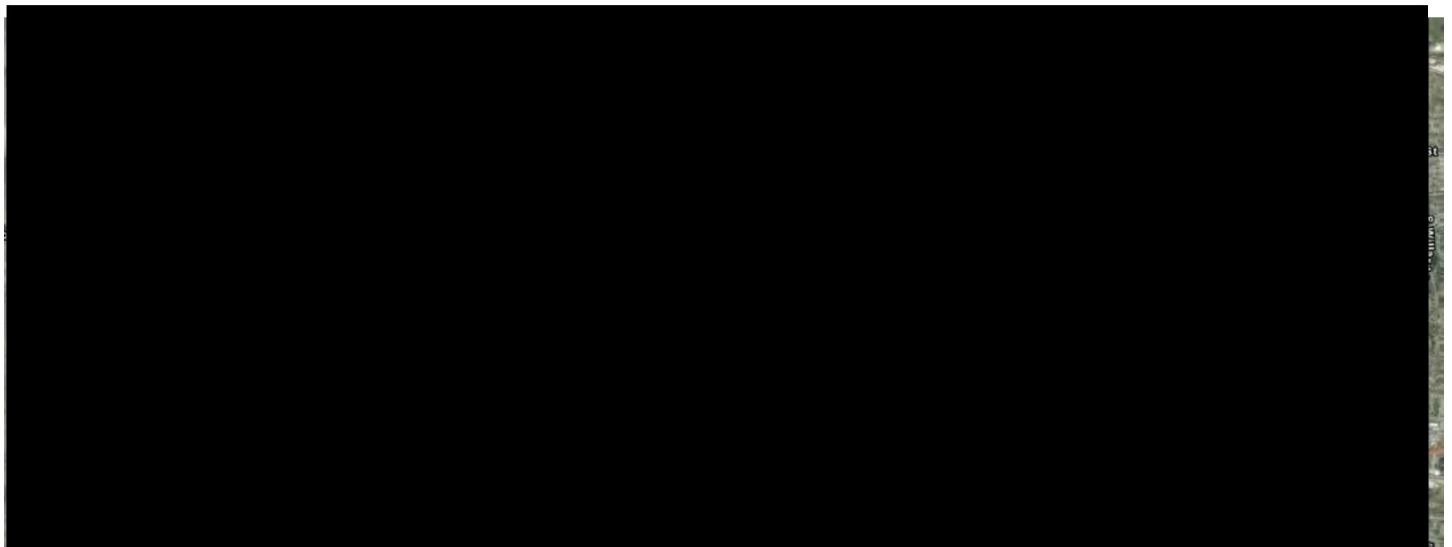

LC-22 GIS Screenshot – July 2023



REVISION HISTORY

REV.	DATE	AUTHOR	APPROVAL	COMMENT
0	01/18/2024	K. Peoples	N. Henderson	Issued for DPS Approval
A	07/26/2023	K. Peoples	N. Henderson	For Internal Review



CONTENTS

1	INTRODUCTION	5
2	CROSSING ARRANGEMENT	6
2.1	Crossing Design	6
2.2	Installation	8
2.2.1	Pre-Lay Works	8
2.2.2	Cable Lay	8
2.3	Schedule	8
3	SURVEY	9
3.1	CHPE Marine identification and confirmation process	11
4	TECHNICAL DATA	12
4.1	CHPE Cable Specification	12
4.2	CHPE Splicing	12
4.3	Ampacity & Thermal Impacts	12
4.4	Induction, Impedance & Corrosive Potential	12
5	SAFETY SYSTEMS	13
6	CABLE REPAIR	14
6.1	CHPE Cable Repair	14
6.1.1	Not Impacting Crossing(s)	14
6.1.2	Impacting CI Crossing(s)	14
6.2	CI Cable Repair	14
6.2.1	Not Impacting CHPE	14
6.2.2	Impacting CHPE Crossing	15
7	OPERATIONS AND MAINTENANCE	16
7.1	Operations Monitoring	16
7.2	Scheduled Maintenance (marine)	16
7.3	Unscheduled maintenance	16



8	DECOMISSIONING	17
APPENDIX A.	CROSSING DESIGN	18
APPENDIX B.	URAGUARD DUCT SYSTEM	21
APPENDIX C.	SURVEY DATA.....	23
APPENDIX D.	CHPE CABLE SPECIFICATION	52
APPENDIX E.	CHPE CABLE SPLICE.....	59
APPENDIX F.	THERMAL & AMPACITY STUDY	62
APPENDIX G.	ELECTRICAL EFFECTS STUDY.....	75



1 INTRODUCTION

The Champlain Hudson Power Express is a 1,250-megawatt underwater/underground high-voltage direct current (“HVDC”) transmission system that will deliver clean hydropower from resources in Quebec, Canada directly to New York City. The Facility was issued a Certificate of Environmental Compatibility and Public Need under Article VII of the New York State Public Service Law (“Certificate”) in April 2013; this Certificate is held by CHPE LLC and CHPE Properties, Inc. (“Certificate Holders”).

CHPE LLC will construct, operate, and maintain the U.S. facilities. The HVDC transmission line runs approximately 339 miles from the New York/Canada border to a converter station located in Astoria, Queens. The HVDC cable system will consist of two 400KV solid dielectric cables with a fiber optic control. The route runs through Lake Champlain, terrestrial upland sections, the Hudson and Harlem rivers to a converter station located in Astoria, Queens

As part of the construction of the Marine Transmission Facilities the cable will cross a number of existing third-party assets.

This document details the proposed arrangement for crossing of collocated infrastructure (“CI”) here, an unknown diameter line, suspected to be a Telecom or Power Cable (referred to on plans as LC-22) where CHPE, after making commercially reasonable efforts described herein, have been unable to identify and connect with an owner.

This document demonstrates the commercially reasonable efforts made by CHPE to identify the CI owner. Given the lack of an identifiable CI owner, it also details the measures CHPE proposes to utilize to protect the CI at the location of the CHPE Facility’s crossing by installing pre- and post-installation utility protection measures appropriate to this type of utility.

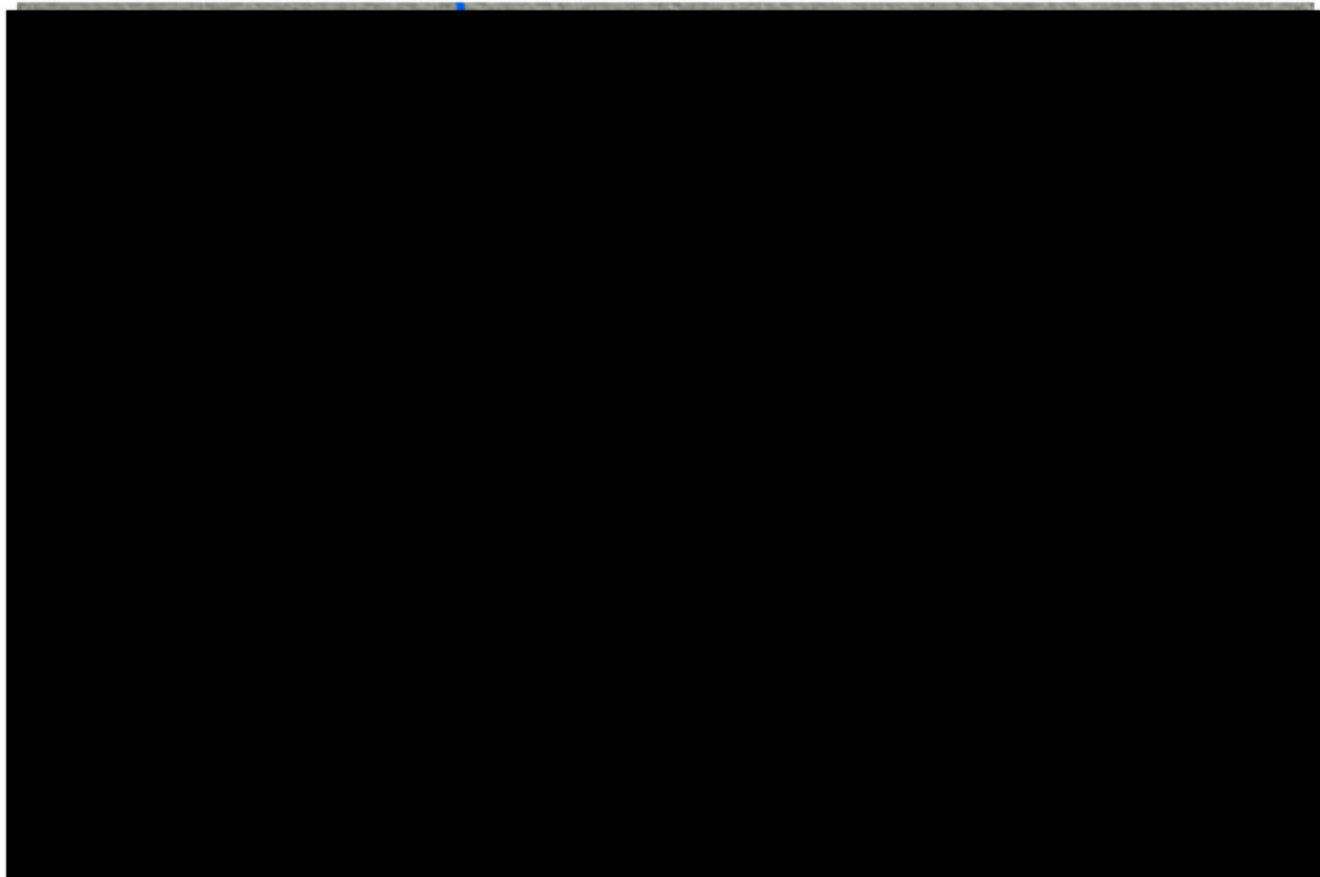

Figure 1-1: LC-22 GIS Screenshot - July 2023

2 CROSSING ARRANGEMENT

As part of the construction of the CHPE Marine Facilities, the CHPE HVDC Cable will be laid along the Lake Champlain lakebed. Where possible, the Cable route has been selected to avoid crossing or impacting third party CI assets to the maximum extent practicable, as directed in CHPE's Article VII Certificate. In the case of the LC-22 cable running nominally east-west across Lake Champlain, no viable alternative to crossing this CI was identified.

The crossing design has been selected based on industry best practice and the crossing of similar assets in the vicinity of this unknown owner crossing.

2.1 CROSSING DESIGN

The crossing design will utilize a protective duct (Uraguard or similar shown in Figure 2-1 and APPENDIX B) that will bundle the CHPE cables and provides additional impact and abrasion resistance to both CHPE and the unknown owner asset. The protective duct will extend ~100' either side of the crossing for a total of ~200' of ducting Figure 2-2.

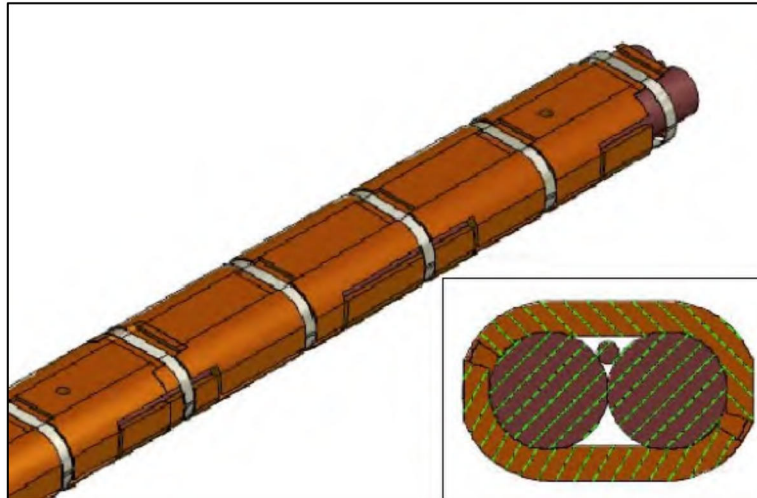

Figure 2-1: UraDuct (or Similar) Cable Bundle

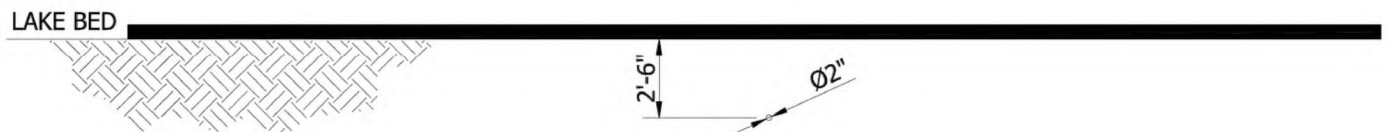

Figure 2-2: LC-22 Crossing Design Profile

The CHPE cables will cross the LC-22 cable with a relative crossing angle of $\sim 119^\circ$ at a water depth of approximately 210-feet.

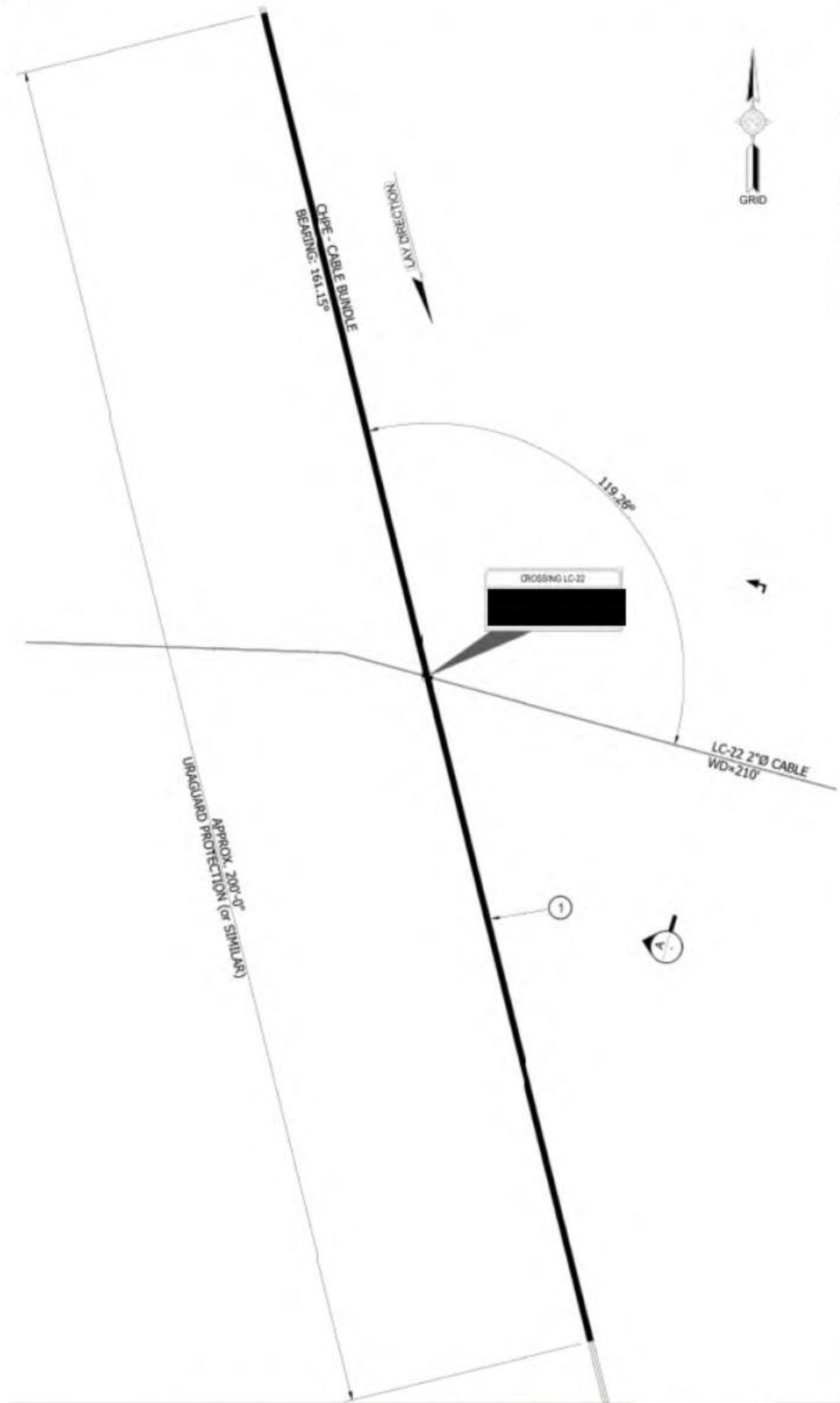

Figure 2-3: LC-22 Crossing Arrangement Plan



2.2 INSTALLATION

2.2.1 PRE-LAY WORKS

Prior to installation of any permanent works, a significant number of surveys and investigations have been undertaken to aid the route design and optimization (further detailed in Section 3).

No pre-lay intervention works are foreseen for the agreed crossing arrangement of the Unknown cable (LC-22) in Lake Champlain.

2.2.2 CABLE LAY

During CHPE cable laying activities the bundled cables will be laid using a dynamically positioned (DP2) barge.

Due to water depth, the cable in this location will be laid on the lakebed surface either side of the Unknown fiber.

During cable lay, the touchdown point of the cable will be monitored by a remotely operated vehicle (ROV).

On completion of cable lay, as-built locations of the CHPE cables will be accurately recorded and used to update:

- CHPE Project GIS system;
- Cable installation route overlays for cable; and,
- Relevant Authorities (USACE, USCG, NOAA etc.).

2.3 SCHEDULE

The activities and expected schedule/durations related to the crossing of the LC-22 crossing are detailed in Table 2-1.

Table 2-1: Schedule

Activity	Duration (Days)	Scheduled Date
Cable Lay	1	July 2024



3 SURVEY

Extensive surveys have been undertaken to facilitate design and routing of the CHPE project, including the locating of third-party assets' collocated infrastructure.

The Unknown cable has been confirmed using survey techniques described below. Note that no diver locates have been conducted on the Unknown asset due to water depths.

Surveys conducted include:

2012

- Desktop study: to research existing information on as-built positions and utility ownership for charted cable and pipeline areas.
- Hydrography (multibeam depth sounder): to determine water depths and reveal any topographic relief that may be associated with an exposed utility.
- Bottom imaging (side scan sonar): to identify geomorphologic variations and man-made targets marking linear trends suggestive of an exposed utility.
- Magnetic intensity measurements (magnetometer): to measure variations in the earth's total magnetic field to identify the magnetic signature of a utility.
- Sub-bottom profiling (chirp): to reveal shallow subsurface seismic reflectors that might be characteristic of a buried utility and its surrounding construction features.

2020

- Diver locates by Caldwell Marine International LLC (CMI).

2022

- Ocean Surveys Inc. completed a multi-sensor survey of route on behalf of CMI.

2023

- S.T. Hudson completed a multi-sensor survey of route on behalf of CHPE using sophisticated and upgraded equipment compared to previous studies.
- Follow up diver locates by Caldwell Marine International LLC (CMI) to all shallow water S.T. Hudson targets.
- FOIA requests to NOAA, USACE and USCG.

Formal third-party surveys are detailed in Table 3-1 below.



Table 3-1: Formal 3rd Party Surveys

Survey Date	Company	Description
July 2010	Rogers Surveying LLC	Geophysical, Sediment and Benthic Not used for locating Co-Located Infrastructure (CI)
Sep to Oct 2012	Ocean Surveys Inc.	The 2012 MRS was designed to provide pertinent data and results in support of the CHPE Project to: (1) characterize/evaluate bottom conditions and underlying shallow stratigraphy along segments of the route that had not been previously surveyed, (2) acquire additional detail to better understand areas exhibiting complex or unique site conditions, (3) acquire additional geophysical detail at sites where potential cultural resources were identified from the 2010 MRS, and (4) locate existing submarine utilities. Ref: OSI_CHPE_2012-Utility-Report_Final-Vol3_01-29-13
Q3 2020	Caldwell Marine International LLC (CMI)	Diving investigation of utilities identified by previous reports. Ref: C1208-CHPE(LAKE)-UTILITY LOCATE REPORT-ISSUE 2.0-20201006 (1)
Q3 2022	Ocean Surveys Inc. for CMI	Multi sensor survey of the Lake Champlain Marine route Ref: Submittal 060-01-0 Pre-Lay Survey Results - Lake Champlain & 060-01-0 Appendix 1 - Magnetic Anomalies
Q2 2023	S.T. Hudson	Multi sensor survey of Lake Champlain Route Ref: 23-076_TDI_HRG_Lake_Champlain_Final_Report_Rev1
Q2 2023	Caldwell Marine International LLC (CMI)	Diving investigation of utilities identified by previous reports. Following the S.T. Hudson survey. C1235-CHPE(LC)-UTILITY LOCATE REPORT-ISSUE 1.0-20230728

Survey data obtained, relevant to LC-22, is presented in APPENDIX C for information.



3.1 CHPE MARINE IDENTIFICATION AND CONFIRMATION PROCESS

CHPE has attempted to ascertain the owners of CI identified in the CI locate efforts described above through a number of methods, including outreach to other nearby submarine CI owners, submission of Freedom of Information Act/Law (FOIA/L) requests to state and federal agencies, review of terrestrial property records along the shore of Lake Champlain to identify on-shore CI-owned tax parcels in the vicinity of unidentified submarine CI assets.

- Email received from AT&T on 2/28/23 confirming that the unknown crossings are not owned by AT&T.
- Virtual meeting with Vermont Telephone (VT) held 4/3/23 confirming that the unknown crossings are not owned by VT.
- Virtual meeting with NYPA held 5/11/23 confirming that the unknown crossings are not owned by NYPA.
- FOIL request made to NYSOGS on 3/1/23 for easement information on submarine cables and utilities crossing the CHPE route. Response documents received 4/4/2023. No owners of unknown crossings were identified following review of NYSOGS documents.
- FOIA request made to National Oceanic and Atmospheric Administration (NOAA) on 3/1/23 for owner information on charted submarine cables and utilities crossing the CHPE route. Response documents received 4/26/2023. No owners of unknown crossing were identified following review of NOAA documents.
- FOIA request made to USACE on 3/1/23 and revised on 4/4/23 for permit information on submarine cables and utilities crossing the CHPE route. Response documents received 5/11/2023. No owners of unknown crossings were identified following review of USACE documents.
- FOIA request made to USDOD NGA on 3/1/23 for ownership information on submarine cables and utilities crossing the CHPE route. No response documents received to date. Seven follow-up calls made between 6/1/23 and 7/31/23 requesting status update. No response expected.
- NYS UDig engineering tickets submitted 7/12/2023 requesting notification of all crossed utilities along Lake Champlain. Responses pending. No owners of unknown crossings were identified based on responses received to date.
- Calls with Plattsburgh Airforce Museum, SAC/STRATCOM, and Former Airforce Base Engineering Supervisor between 7/14/23 and 7/28/23 requesting information on ownership information of LC-08, LC-08A, LC-09A, LC-09B, LC-10, LC-11, LC-12, and LC-13. None had records of utilities or easements.
- Calls and emails with Lake Champlain Ferry Company requesting easement records and owner information for LC-20, LC-20A & LC-20B from 7/14/23 to 7/28/23. Owner was identified as historic NY Telephone Company by easements provided by Lake Champlain Ferry Company. Cable is abandoned with no active owner.

CHPE will retain all records of these efforts as part of the Project completion documentation package.

These efforts, taken together, constitute all commercially reasonable efforts to identify the owners of CI assets identified in the vicinity of the CHPE Facility during the submarine identification process described above, including LC-22.

At this time, it is not practicable to require further efforts to identify the owners of these CI assets, particularly in light of the New York Independent Systems Operator's (NYISO's) findings that the CHPE Facility must be constructed and placed in service by spring 2026 to aid in avoiding significant threats to reliability within the New York State electric grid.

While it is possible that CI assets like LC-22 are abandoned and that owners cannot be located because they no longer exist, CHPE has opted to take a conservative approach and to install standard pre- and post-lay utility protection measures materially similar to those utilized for other submarine utilities of the same type (telecommunications, electric, gas, etc.), which will ensure the identified CI is protected consistent with CHPE's Certificate and as though it is still an actively used utility asset.



4 TECHNICAL DATA

Condition 162 of CHPE's Certificate requires technical analysis demonstrating that the collocation of the CHPE Facility with other nearby CI will not adversely affect that CI, including an assessment of potential ampacity and thermal impacts, induction, impedance, and corrosive potential, and so on. While the owner of the CI addressed in this package is unknown, CHPE has nevertheless performed these analyses to demonstrate no adverse impact to the CI in question and provides the results of those analyses herein. Technical data related to the CI crossing location is summarized in this section; full reports included as appendices.

4.1 CHPE CABLE SPECIFICATION

The CHPE Facility includes a DC cable circuit with two 2,500mm² copper conductor cross-linked polyethylene (XLPE) insulated cables rated ±400 kV DC to ground and a 48 core fiber optic control and monitoring cable.

See APPENDIX D for CHPE Marine Cable Specifications.

4.2 CHPE SPLICING

The CHPE cable splice is presented for information only. Splice locations are designed to avoid CI crossing locations. (See APPENDIX E for cable splice layout).

Note that there are 7 (seven) planned submarine splice locations in Lake Champlain.

4.3 AMPACITY & THERMAL IMPACTS

Thermal and ampacity effects at the crossing location are presented in APPENDIX F.

4.4 INDUCTION, IMPEDANCE & CORROSIVE POTENTIAL

The electrical effects of the CHPE cables on CI is presented in APPENDIX G.



5 SAFETY SYSTEMS

A break or severing of the HVDC conductor is referred to as a DC line fault. The magnitude of the DC fault current will depend on the impedance of the DC circuit, the location of the fault, the capacitance of the DC cable as well as the sizing of the converter arm reactors. However, since the cable itself does not contain any combustible material there is negligible risk of explosion. In the case of a fault, the converter protection system will disconnect the converter and cable system from the electrical transmission system within 100ms. The fault path will be from the conductor to the cable metallic sheath and then back to the source.

If the HVDC cable is severely damaged, for example by an anchor strike, and an electrical breakdown occurs in the cable, the power on the cable will be isolated as mentioned above. At the position of the electrical breakdown, a flashover will occur between the conductor and the metallic screen due to the discharge of the cable. The conductor and the metallic screen is designed to carry the fault current.

A fiber optic cable system is being installed as part of the cable bundle along the entire route to monitor the power cables within the terrestrial and submarine sections. The fiber optic cable monitors temperature and any acoustic noises and/or vibrations near the cable. In addition, there will be two (2) communication 1 GB ethernet channels between HQ's Hertel Converter Station and the Astoria Converter Station with feeds to 5 in-line, land-based monitoring stations spread along the route.

The monitoring system will be capable of detecting:

- Hot-spot detection along cables: Monitoring of power cables for potential hot-spot along the whole circuit using the installed fiber-optic sensing system.
- External hot-spot detection: Monitoring of potential unwanted external thermal sources to the integrity of the underground surroundings.
- Mechanical Intrusion detection: Monitoring of vessels anchoring or third-party intrusion ("TPI") all along the underground lines to protect the asset against unwanted activities in the vicinities of the circuit such as manual and mechanical digging.

In the event of any detected faults, the system may be shut down by either Hertel or Astoria converter stations.



6 CABLE REPAIR

From time to time throughout the CHPE Facility's life, repairs above or near the Unknown CI crossing may be necessary. Detailed design/procedures for repair of the facility will be developed based on the type of repair and the extent of damage. General procedures for how a repair will be performed are included in the following sections. Further details on planned repair procedures will be contained in the Maintenance and Emergency Action plan, to be submitted with the overall facility Operations and Maintenance manual, prior to operations. However, the CI protection measures to be used with respect to this Unknown CI owner's crossing during operations will be consistent with those used for submarine CI of a similar utility type (telecommunications, gas, electricity, etc.) elsewhere in Lake Champlain to ensure that this CI is protected from damage during the operation of the CHPE Facility.

In general, repair-related maintenance will require careful planning and regulatory coordination by CHPE. Qualified repair contractor(s) would be dispatched to the work location. A portion of the transmission cable would be raised to the surface, the damaged portion of the cable cut and removed, and a replacement section of spare cable would be spliced.

Once repairs were completed, the transmission cable would be re-laid on the lakebed and re-buried using ROV/diver jetting devices or laid on bottom with additional protection (as required), depending on location. In the event repairs are required, they will comply with regulatory requirements and permit conditions.

6.1 CHPE CABLE REPAIR

6.1.1 NOT IMPACTING CROSSING(S)

If a repair of the CHPE cable(s) does not impact any utility crossing, the CHPE cable will be cut and recovered for splicing. A section of cable would be spliced in to accommodate replacing the damaged section, and the repaired cable lowered to the seabed. The repaired cable would be deployed and reburied to the required depth using remedial burial techniques, i.e., ROV or diver operated jet sled, or protected using articulated concrete mattresses (as required).

6.1.2 IMPACTING CI CROSSING(S)

If a repair is required which impacts the collocated infrastructure, the utility owner would typically first be notified of the repair. In the case of Unknown CI owners, CHPE will notify NYSDPS and other regulators as appropriate, affirming that repairs near an Unknown CI asset will be undertaken consistent with this plan. Repair will be completed using standard industry practices with pre- and post-lay protection used as necessary to protect both the CHPE Facility and the Unknown CI.

6.2 CI CABLE REPAIR

6.2.1 NOT IMPACTING CHPE

If a repair of the collocated infrastructure does not impact CHPE Cables, CHPE is to be notified of the requirement for a repair and location to determine if it may impact existing cable protection arrangements. Schedules and notifications of repair start/completion dates for purposes of monitoring the CHPE system for service disruptions shall also be provided. CHPE will file as-built drawings and other information to appropriate State and Federal regulators to ensure the location of the CHPE Facility is known by other CI owners, and will register with the New York UDig program as required by the Certificate, to ensure other current or future CI owners are aware of the CHPE Facility and contact CHPE of nearby repair work.



6.2.2 IMPACTING CHPE CROSSING

In general, if a repair of collocated infrastructure impacts CHPE cables, the collocated infrastructure should be cut on either side of the CHPE cables to prevent disturbance to CHPE and crossing protection. The existing utility should be repaired using standard industry practices and then laid back out. Pre- and post-lay protection shall be agreed in a formal crossing agreement between both owners and installed as necessary to protect both utilities. If, in the future, an Unknown CI owner comes forward to claim ownership of LC-22, CHPE will require discussion of crossing arrangements and work near the CHPE line before such work could proceed.



7 OPERATIONS AND MAINTENANCE

As the owner, CHPE LLC will be responsible for ensuring the long-term successful operation of the Project over its 80+year design life. System performance will be continuously monitored from several locations by a dedicated O&M Team to ensure proper operation of the system. This monitoring will allow for immediate fault detection and instantaneous feedback on any operational deviations which may prevent the system from functioning optimally.

The Astoria (NY) and Hertel (Quebec) Converter Stations will be continuously staffed by the O&M Team with notifications, monitoring, and control protocols established and integrated as part of the overall automated operation of the system.

The CHPE Project is projected to come online in May 2026.

The transmission line's facilities in Canada, including an HVDC converter station in Hertel, Quebec, will be constructed, operated, and maintained by Hydro Quebec and its affiliates. CHPE LLC will construct, operate, and maintain the U.S. facilities including marine and terrestrial cable sections, the Astoria Converter Station, and the Operations Control Center.

7.1 OPERATIONS MONITORING

A fiber-optic cable monitoring system is being integrated into the cable bundle to actively monitor the HVDC cables along the entire HVDC power cable route, both terrestrial and submarine. As well as the main stations in Hertel and Astoria there are 5 land-based monitoring stations linked to both.

HVDC-system-related control functions are coordinated by both converter stations (Hertel and Astoria), such as starting/stopping power transmission, power/current reference value setting, and controlling DC voltage.

7.2 SCHEDULED MAINTENANCE (MARINE)

Physical Inspections will be undertaken as a minimum every 5 years by remotely operated vehicles ("ROV"), including verification of depth of burial and the integrity of post-lay mattress protection. CHPE plans to undertake these inspections using TSS trackers following an injected tone using the main cores when down for service, or a tone injected in the armoring when in service.

7.3 UNSCHEDULED MAINTENANCE

Two repair equipment storage facilities will be constructed along the Project's route to store and maintain an inventory of long lead items required for repairing possible cable faults. One storage location will have direct access to Lake Champlain and will contain suitable sections of marine cable and associated equipment required for repairs.

Section 6 further describes the expect repair scenarios. Dedicated repair procedures and plans will be shared in the event of a required repair in proximity to facilities described in this document.



8 DECOMMISSIONING

Decommissioning of the CHPE cables will involve the permanent abandonment on the lakebed, consistent with CHPE's permits.



APPENDIX A. CROSSING DESIGN

[2 Pages]

LEGEND

- 2530+00 STATIONING (FEET)
- PROPOSED CABLE ROUTE
- 48 MILE POSTS (STATUTE MILE)
- SUBMARINE CABLE CHARTED UTILITY
- NEW YORK - VERMONT STATE LINE
- LIMIT OF ALLOWED DEVIATION ZONE (20-FT WATER DEPTH IN NOAA LOW WATER DATUM = +72.5-FOOT ELEVATION - NAVD88)
- +75 5-FOOT CONTOUR (NAVD88)
- +72 1-FOOT CONTOUR (NAVD88)

- REFERENCE NOTES**
- LAKE CHAMPLAIN BASE PLAN AND BATHYMETRIC DATA PREPARED BY OCEAN SURVEYS INC. AND PROVIDED BY CALDWELL MARINE IN FEBRUARY 2023.
 - CHARTED UTILITIES MAPPED BY OCEAN SURVEYS AND INCLUDED IN ABOVE REFERENCED BASE PLAN. CHARTED UTILITY LOCATIONS SHOWN IN GRAY WITH ITALICIZED TEXT.
 - UTILITY CROSSING LOCATION INFORMATION PROVIDED BY THE CERTIFICATE HOLDERS IN MARCH AND JUNE 2023.
 - UTILITY CROSSING PROTECTION DETAILS PROVIDED BY NKT, INC. ON AUGUST 14, 2023.
- COORDINATE SYSTEM NOTES:**
- HORIZONTAL: UTM WITH NAD83 DATUM, ZONE 18, U.S. SURVEY FOOT (UTM83-18F).
 - VERTICAL: NAVD88.
- INSTALLATION NOTES:**
- REFER TO SECTION 11.2 OF THE PROCEDURAL DOCUMENT, CHAMPLAIN HUDSON POWER EXPRESS, SHALLOW MATTRESS PLACEMENT (<150FT WATERDEPTH), (LAKE CHAMPLAIN SEGMENT), DATED JANUARY 30, 2023, PREPARED BY CALDWELL MARINE INTERNATIONAL, LLC, APPENDIX F OF THE EM&CP, FOR ADDITIONAL PRE-LAY MATTRESSING INSTALLATION DETAILS.
 - FOR UTILITY CROSSINGS IN WATER DEPTHS GREATER THAN (>) OR EQUAL TO (=) 150', PROPOSED USE OF POLY-SHELL CLADDING (URADUCT PRODUCT OR SIMILAR) SHALL BE INSTALLED ON PROPOSED SUBMARINE CABLE DURING SUBMARINE CABLE INSTALLATION OVER THE EXISTING UTILITY CROSSING LOCATION(S). REFER TO SECTION 11.2 OF THE PROCEDURAL DOCUMENT, CHAMPLAIN HUDSON POWER EXPRESS, SHALLOW MATTRESS PLACEMENT (<150FT WATERDEPTH), (LAKE CHAMPLAIN SEGMENT), DATED JANUARY 30, 2023, PREPARED BY CALDWELL MARINE INTERNATIONAL, LLC, APPENDIX F, NOTE 2-BULLET 2 OF THE EM&CP.
- DOCUMENT USE:**
- THESE PLANS AND THE CORRESPONDING CAD DOCUMENTS ARE INSTRUMENTS OF PROFESSIONAL SERVICE PREPARED BY TRC ENGINEERS, INC., AND SHALL NOT BE USED, IN WHOLE OR IN PART, FOR ANY PURPOSE OTHER THAN FOR WHICH IT WAS CREATED WITHOUT THE EXPRESSED WRITTEN CONSENT OF TRC ENGINEERS, INC. ANY UNAUTHORIZED USE, REUSE, MODIFICATION, OR ALTERATION, INCLUDING AUTOMATED CONVERSION OF THIS DOCUMENT, SHALL BE AT THE USER'S SOLE RISK WITHOUT LIABILITY OR LEGAL EXPOSURE TO TRC ENGINEERS, INC.
 - CONTRACTOR SHALL NOT RELY SOLELY ON ELECTRONIC VERSIONS OF PLANS, SPECIFICATIONS, OR DATA FILES THAT ARE OBTAINED FROM THE DESIGNERS OR OWNER, BUT SHALL VERIFY LOCATIONS OF PROJECT FEATURES IN ACCORDANCE WITH THE PAPER COPIES OF THE PLANS AND SPECIFICATIONS THAT ARE SUPPLIED AS PART OF THE CONTRACT DOCUMENTS.
 - SYMBOLS AND LEGENDS OF PROJECT FEATURES ARE GRAPHIC REPRESENTATIONS, AND ARE NOT NECESSARILY SCALED TO THEIR ACTUAL DIMENSIONS OR LOCATIONS ON THE DRAWINGS. THE CONTRACTOR SHALL REFER TO THE DETAIL SHEET DIMENSIONS, MANUFACTURER'S LITERATURE, SHOP DRAWINGS, AND FIELD MEASUREMENTS OF SUPPLIED PRODUCTS FOR LAYOUT OF THE PROJECT FEATURES.
- GENERAL NOTES:**
- CROSSING DESIGNS DEPICTED IN THESE PLANS MAY CHANGE IN RESPONSE TO OWNER-SPECIFIC REQUIREMENTS IDENTIFIED DURING ANY ONGOING NEGOTIATIONS. IF NECESSARY, A CHANGE NOTICE WILL BE SUBMITTED AS NEEDED TO UPDATE THE PLANS.
 - IT IS THE CONTRACTOR'S RESPONSIBILITY TO COORDINATE ALL NECESSARY CONSTRUCTION NOTIFICATIONS, PERMITS AND ACTIVITIES WITH THE CERTIFICATE HOLDERS PRIOR TO AND DURING CONSTRUCTION.
 - LOCATIONS OF EXISTING FACILITIES SHOWN ARE APPROXIMATE. CONTRACTOR TO LOCATE AND/OR CONFIRM THE LOCATIONS AND DEPTH OF ALL UTILITIES, PIPELINES OR OTHER OBSTACLES PRIOR TO EXCAVATION. THE CONTRACTOR SHALL NOTIFY THE OWNER AND ENGINEER AND OF A NY UTILITY FOUND THAT MAY AFFECT THE DESIGN DEPICTED HEREIN.
 - CONTRACTOR TO CONTACT THE NEW YORK 811 OR DIG SAFELY NEW YORK, STATE ONE CALL SYSTEM AT LEAST 72 HOURS PRIOR TO CONSTRUCTION.

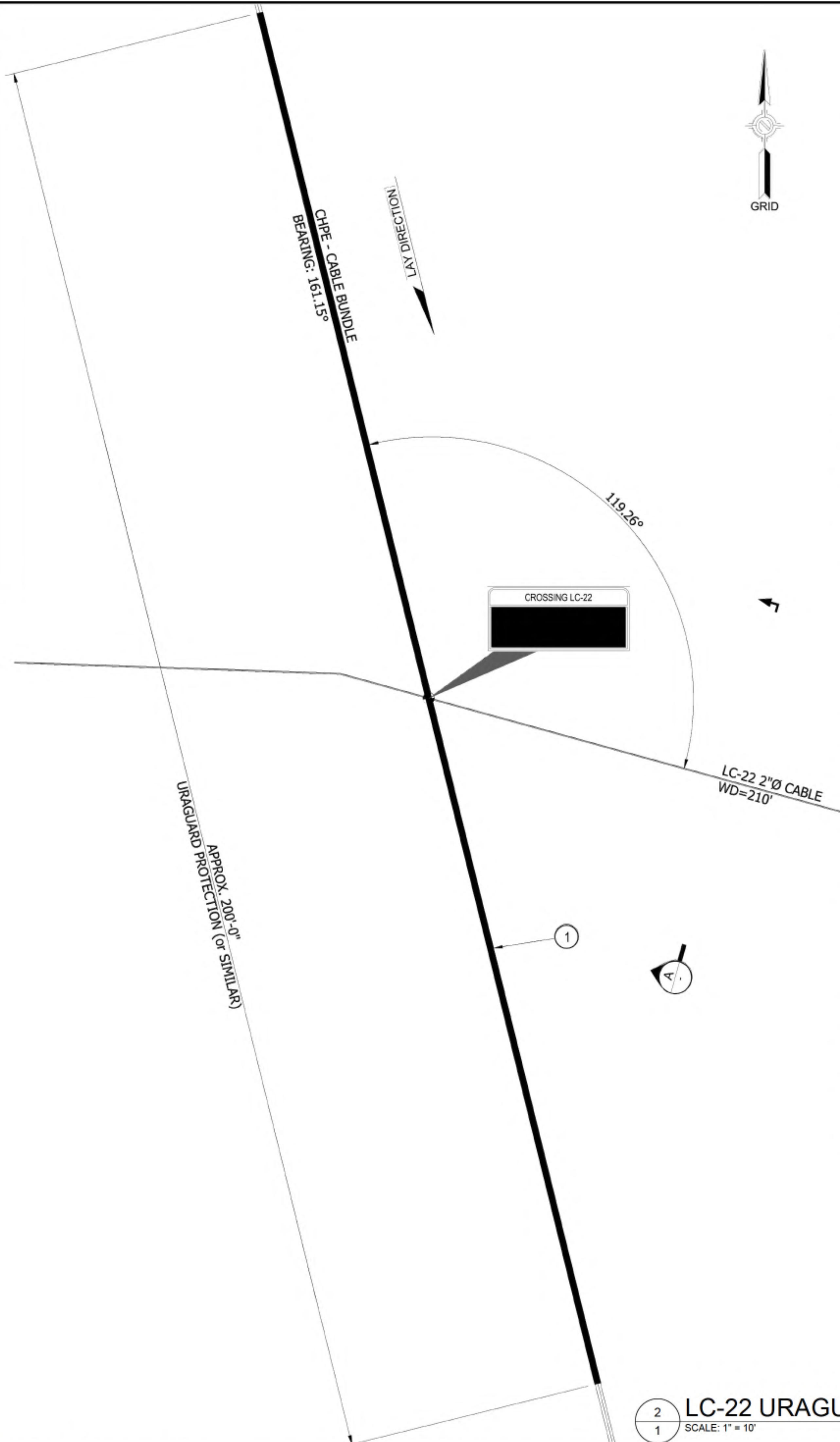
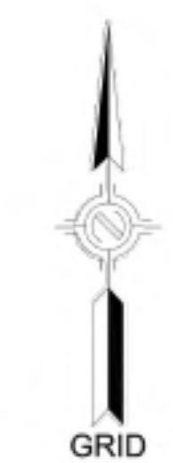

SCALE PLAN: 0 10'

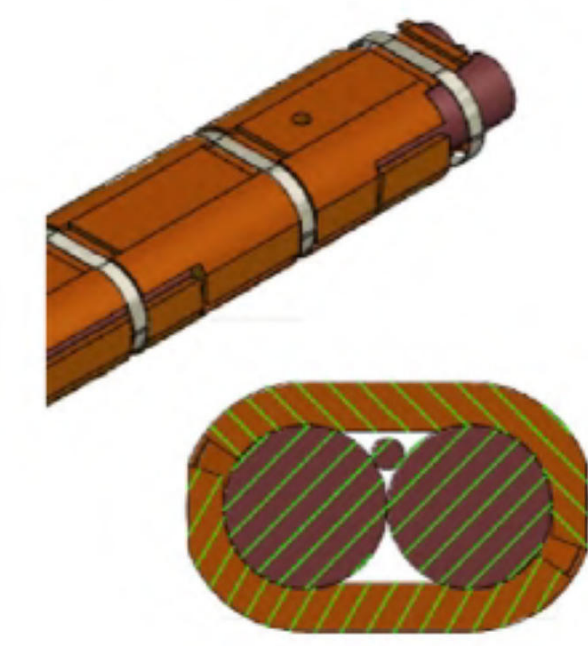

URAGUARD PROTECTION (or SIMILAR)
E: N.T.S.

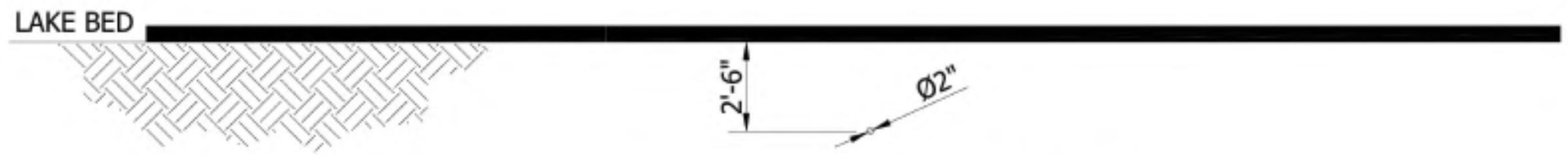

CROSSING ARRANGMENT
VIEW A
SCALE: 1:4

LC-22 URAGUARD CROSSING DETAIL SCALE PLAN: 0 10'



REFERENCE DRAWINGS		REVISIONS					DRAWING APPROVALS	
DWG. NO.	TITLE	NO.	DESCRIPTION	DATE	DRAWN	CHK	APPR	

DRAWING APPROVALS	
DRAWN	DATE
LC	8/25/2023
CHECKED	DATE
GJR	8/28/2023
ENGINEER	DATE
SB	8/30/2023

CHPE - CROSSING PROTECTION PLANS			
LAKE CHAMPLAIN			
CROSSING LC-22			
SCALE	PROJECT NO.	DRAWING NO.	SHT. NO.
AS NOTED	532345	LC-22	1

PRE-LAY
WATER SURFACE

LAKE BED

LAKE BED
WD = 210' ±

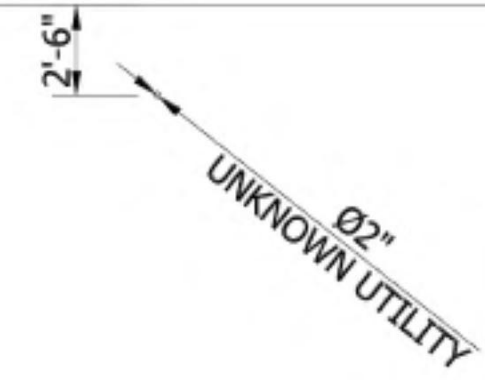

POST-LAY
WATER SURFACE

STEP 1

- INSTALL THE CHPE POWER CABLE BUNDLE ACROSS THE TOP OF UNKNOWN UTILITY.

LAY DIRECTION

CHPE POWER CABLE BUNDLE
W/ URAGUARD PROTECTION

WEIGHT ON BOTTOM	
STEP 1	67 lb/sq ft

LAKE BED

LAKE BED
WD = 210' ±

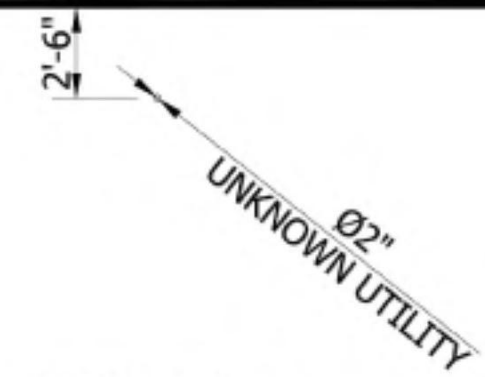

APPROX. 200'-0"
URAGUARD PROTECTION (or SIMILAR)

PREPARED BY:



404 Wyman Street, Suite 375
Waltham, Massachusetts 02451
p 781.419.7696 www.trccompanies.com
FIRM REGISTRATION NO.:
NY 0010187

PREPARED FOR:



We connect a greener world



Steven L. Burke

REFERENCE DRAWINGS

DWG. NO.	TITLE

REVISIONS

NO.	DESCRIPTION	DATE	DRAWN	CHK	APPR

DRAWING APPROVALS

DRAWN	DATE
LC	8/25/2023
CHECKED	DATE
GJR	8/28/2023
ENGINEER	DATE
SB	8/30/2023

**CHPE - CROSSING PROTECTION PLANS
LAKE CHAMPLAIN
CROSSING LC-22**

SCALE	PROJECT NO.	DRAWING NO.	SHT. NO.
NTS	532345	LC-22	2



APPENDIX B. URAGUARD DUCT SYSTEM

[1 Pages]

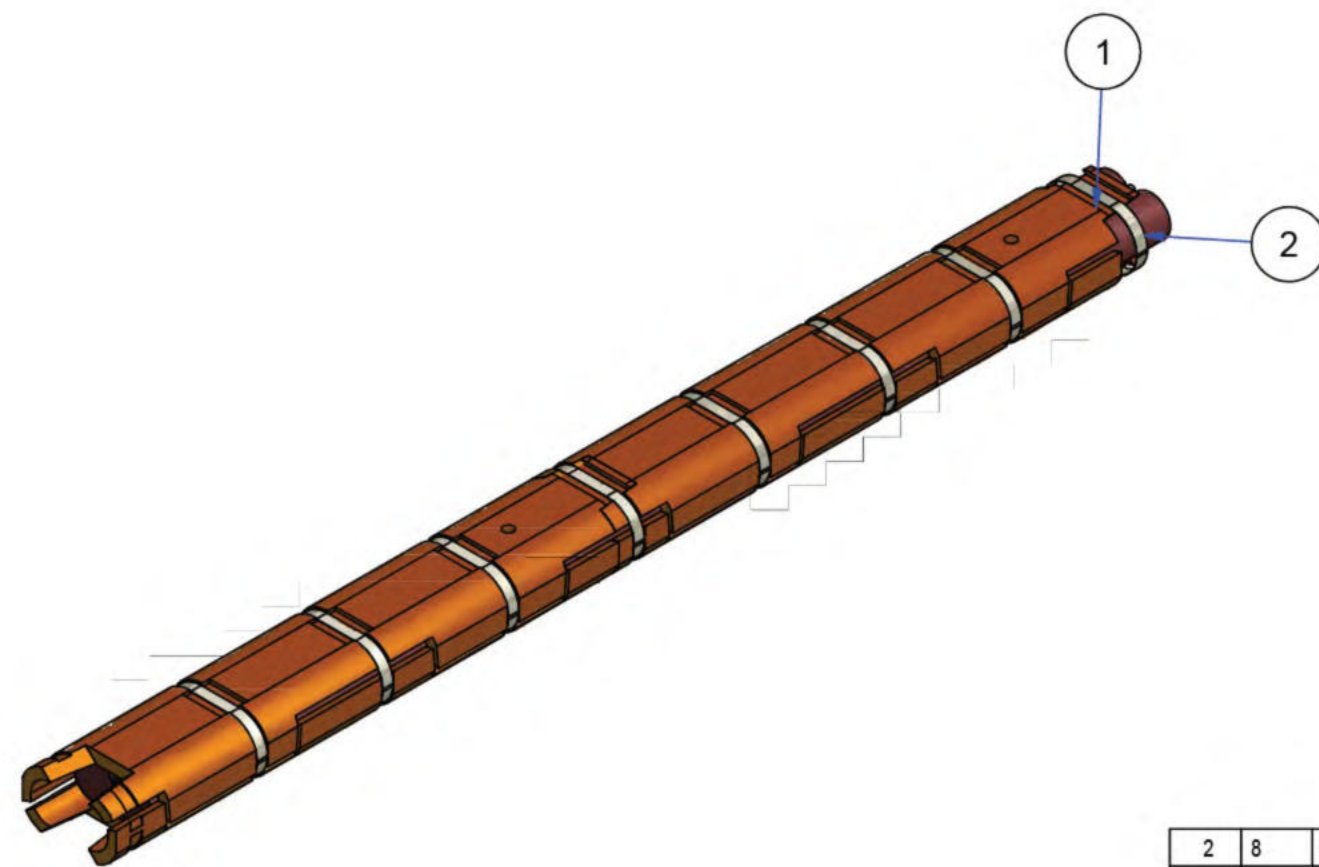
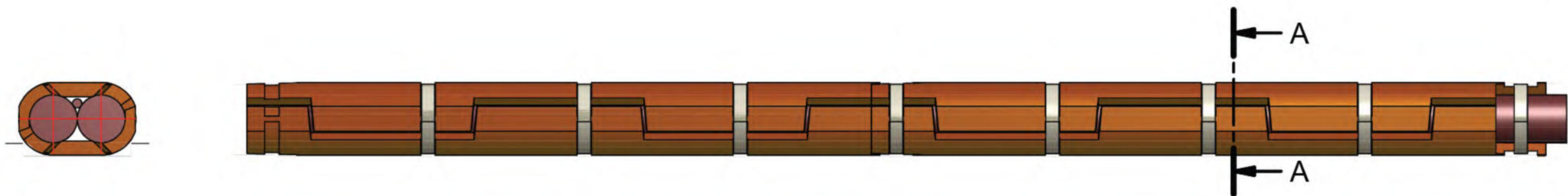

A-A (1:5)

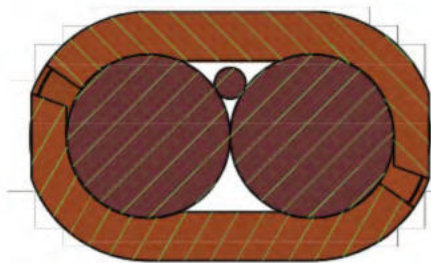

ITEM	QTY	DESCRIPTION	MEASUREMENTS	DWG-NO.	MATERIAL/REMARKS	MASS
2	8	ALLOY STRAPPING	31,75x0,8 L= 1100 (NET CIRC. 750+350)		ALLOY 625, SILVER	0,1 kg
1	4	URAGUARD BUNDLED Ø115x2	1620x279.4x117.4	88F11577-Q	PU, ORANGE SHORE 85A	15,9 kg

**PROPRIETARY
&
CONFIDENTIAL**

TITLE: URAGUARD-BUNDLED CABLES Ø115x2 mm

SUBJECT: ASSEMBLY, 2X DC + FO CABLE

PROJECT:

CLIENT:

DWG.NO.:

REV:

02

COMMENTS:

TOLERANCES UNLESS SPECIFIED: DIMENSIONAL: ±2% WEIGHT: ±10% < 5 kg > ±5%

REV	DATE	BY	DESCRIPTION	CHK	APPR
02	4-6-2012	GL	EXTRA STRAPRECESSES	AW	AvB
01	21-3-2012	GL	UPDATE DESIGN	AW	AvB
00	12-1-2012	MS	FIRST ISSUE	AW	

PARTNO.:	SHEET: 1 OF 1	SCALE: 1:10	UNITS: MM	SIZE: A3	PROJ. METHOD
----------	---------------	-------------	-----------	----------	--------------

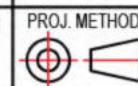

Lankhorst Mouldings
Sneek-Holland



APPENDIX C. SURVEY DATA

[28 Pages]

7.2.4 MP40.4 – CM4

Area CM4 generally shallowed from north to south; NAVD88 elevations were found from -29.51 to -140.55 ft (Figure 34). This site had the greatest elevation change of any of the sites within Lake Champlain. Of the two (2) alignments noted in this area, only CM4_01 had a slight scar in the MBE near the MAG anomalies (Figure 35). Unknown objects and debris of varying sizes were seen across the site, along with scours and depressions.

Magnetometer and SBP data indicated the presence of two (2) alignments in this area. The magnetometer data did not define these assets, but the anomaly amplitude associated with these was very small (Figure 36). Alignment CM4_01 had significantly deeper depth of burial values than any other assets seen in the lake. This alignment corresponded with a steep slope (Figure 35.). The values may be skewed significantly deeper due to this slope.

SBP data in this area provided superb imaging of the subsurface. Bedding of different geologic episodes was clearly visible, as were faulting, gas pockets, and structural movement (Figure 37). Differences in surface bedding corresponded with differences in surface backscatter, indicating these layers were, acoustically, significantly different. The disconformity seen in Areas CM1, CM2, and CM3 was likely present but it had decomposed to the point where it was no longer discernable as a discrete layer. Layered sediment was nearly 20 ft thick in most of the survey area.

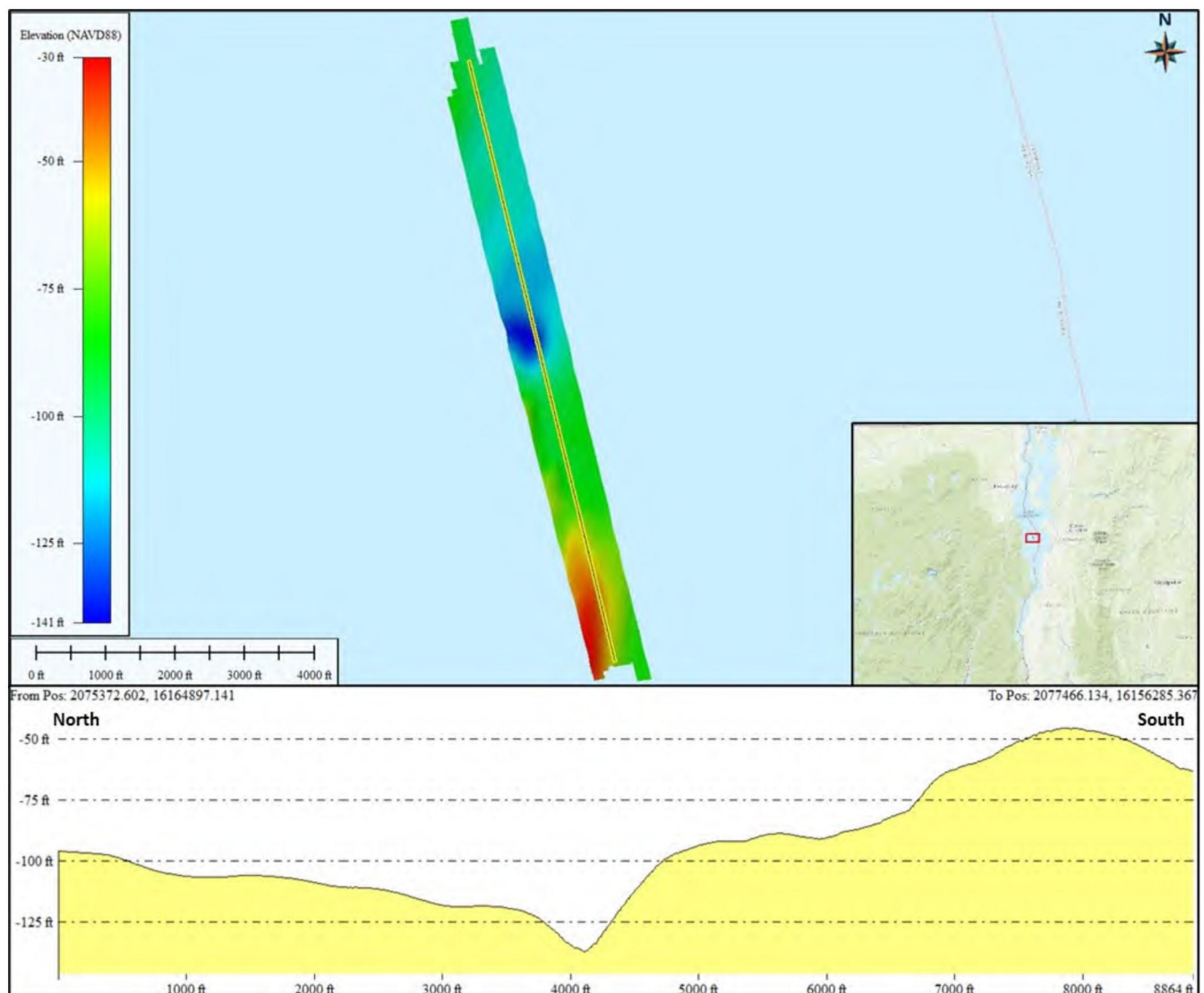

Figure 34. Bathymetric Grid and Profile for Area CM4

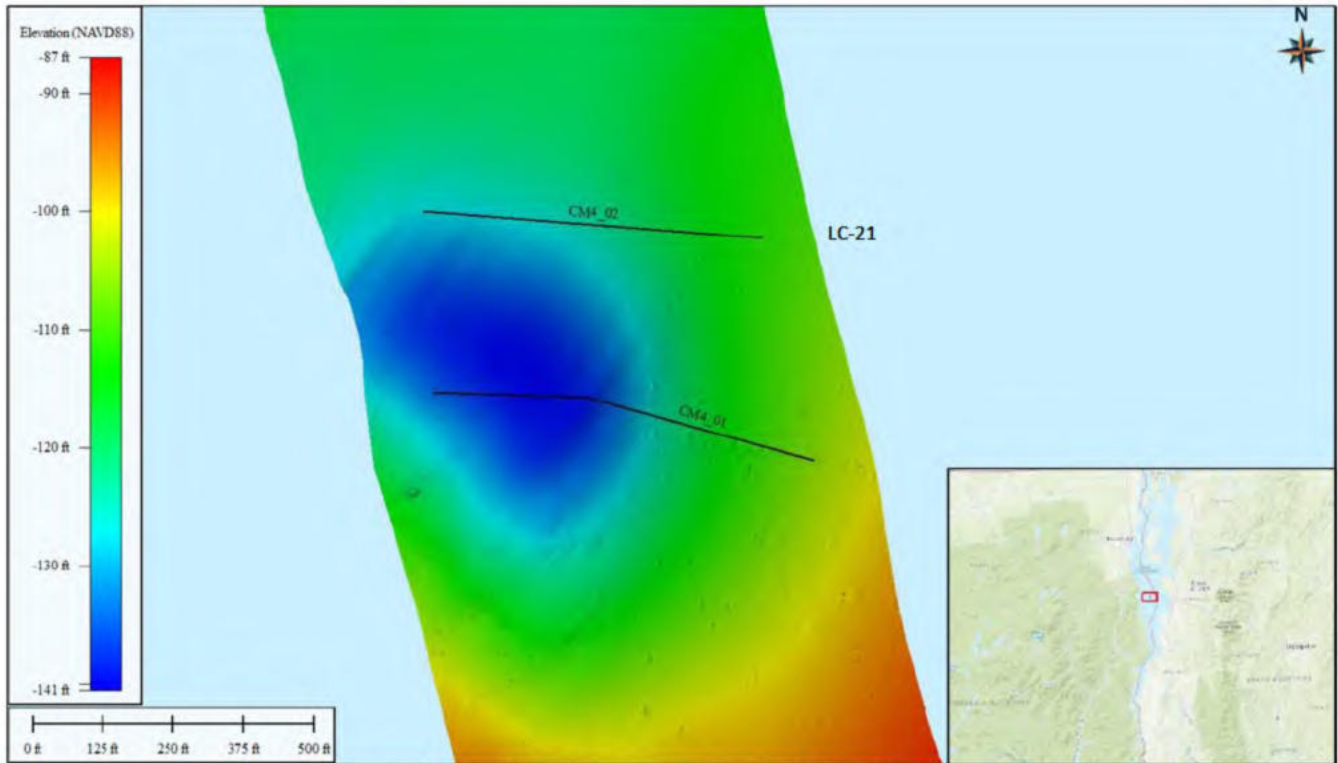

Figure 35. Two (2) Alignments in Area CM4, near deep scour

Table 15. Alignments Found in the Area CM4, MP40.4

NAME	AREA	COMMENTS	DETECTED	POSITIONED	DoB WEST	DoB MID	DoB EAST
CM4_01	CM4	DOC VALUES MAY BE SKEWED DUE TO BATHYMETRIC SLOPES	MAG, SBP	MAG	6.23	5.25	9.84
CM4_02	LC-21	DOC VALUES MAY BE SKEWED DUE TO BATHYMETRIC SLOPES	MAG, SBP	MAG	19.69	18.37	4.76

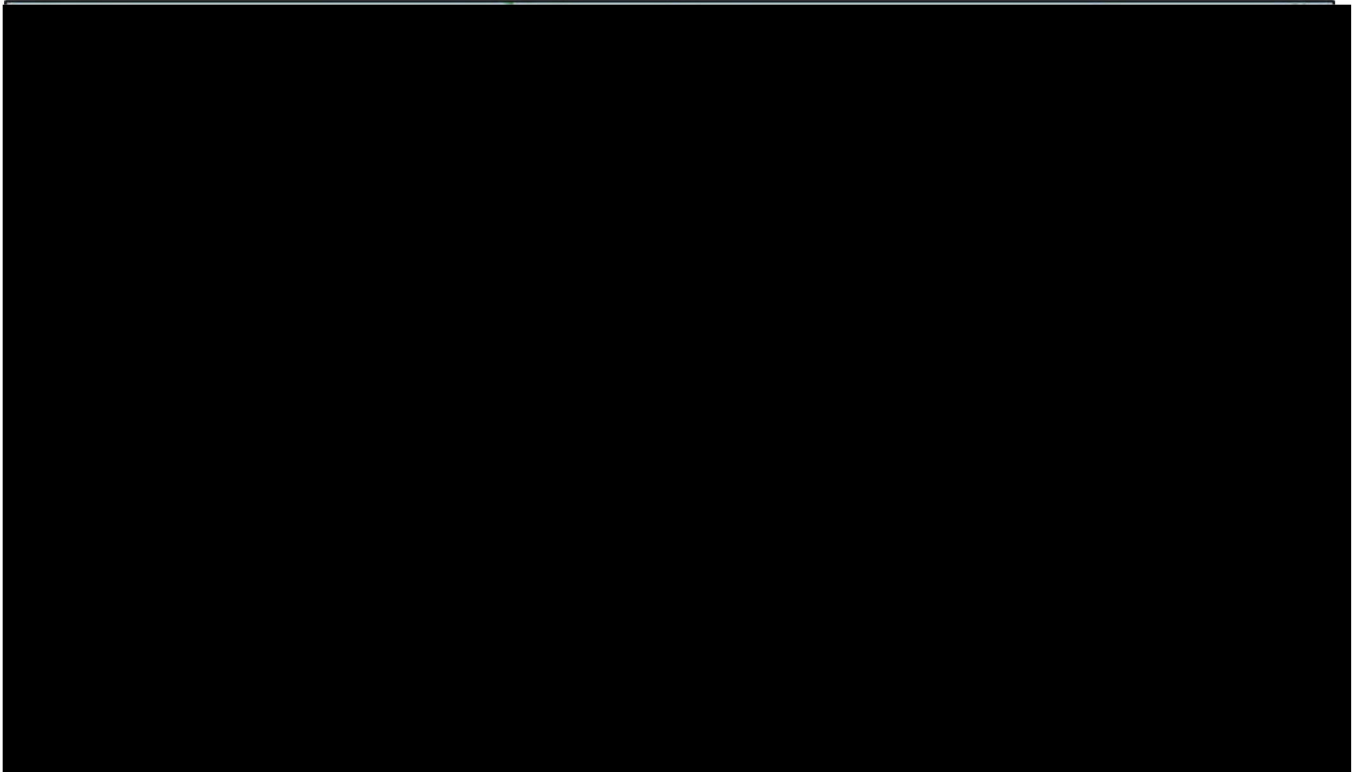

Figure 36. MAG ASIG for Area CM4

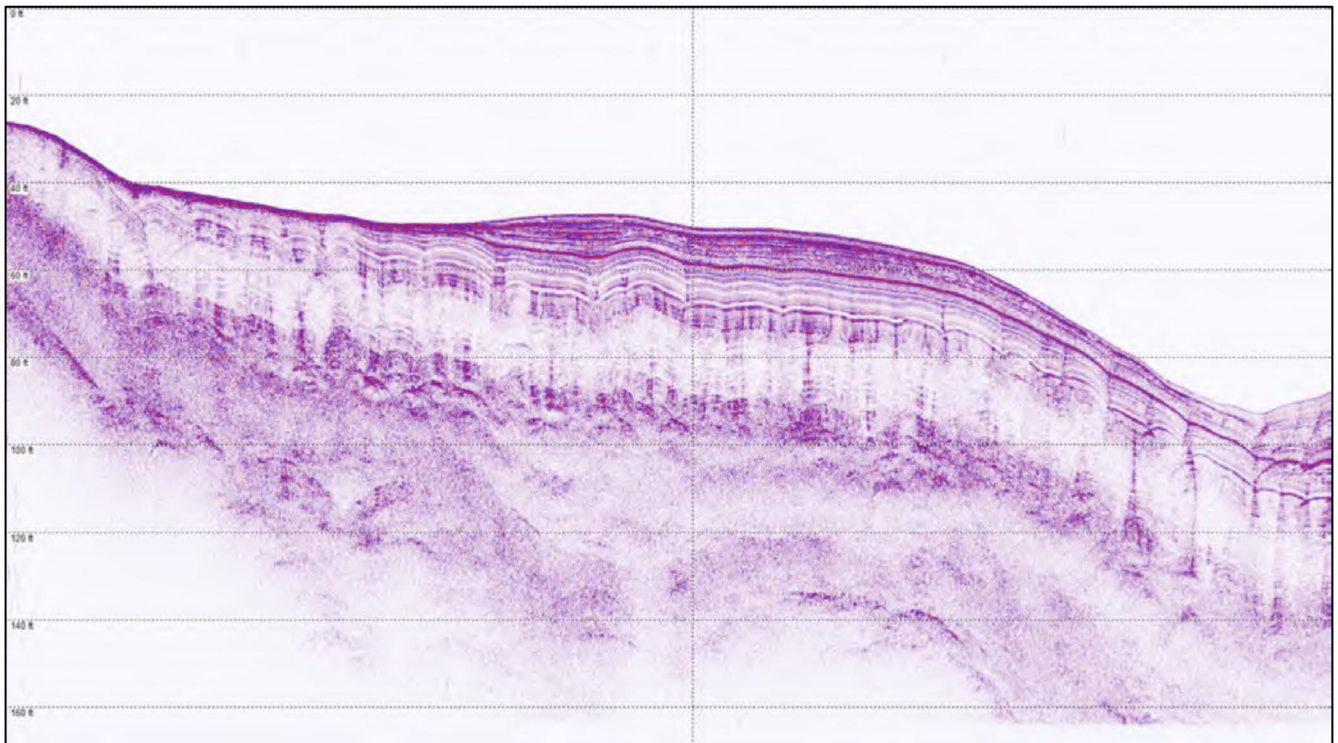
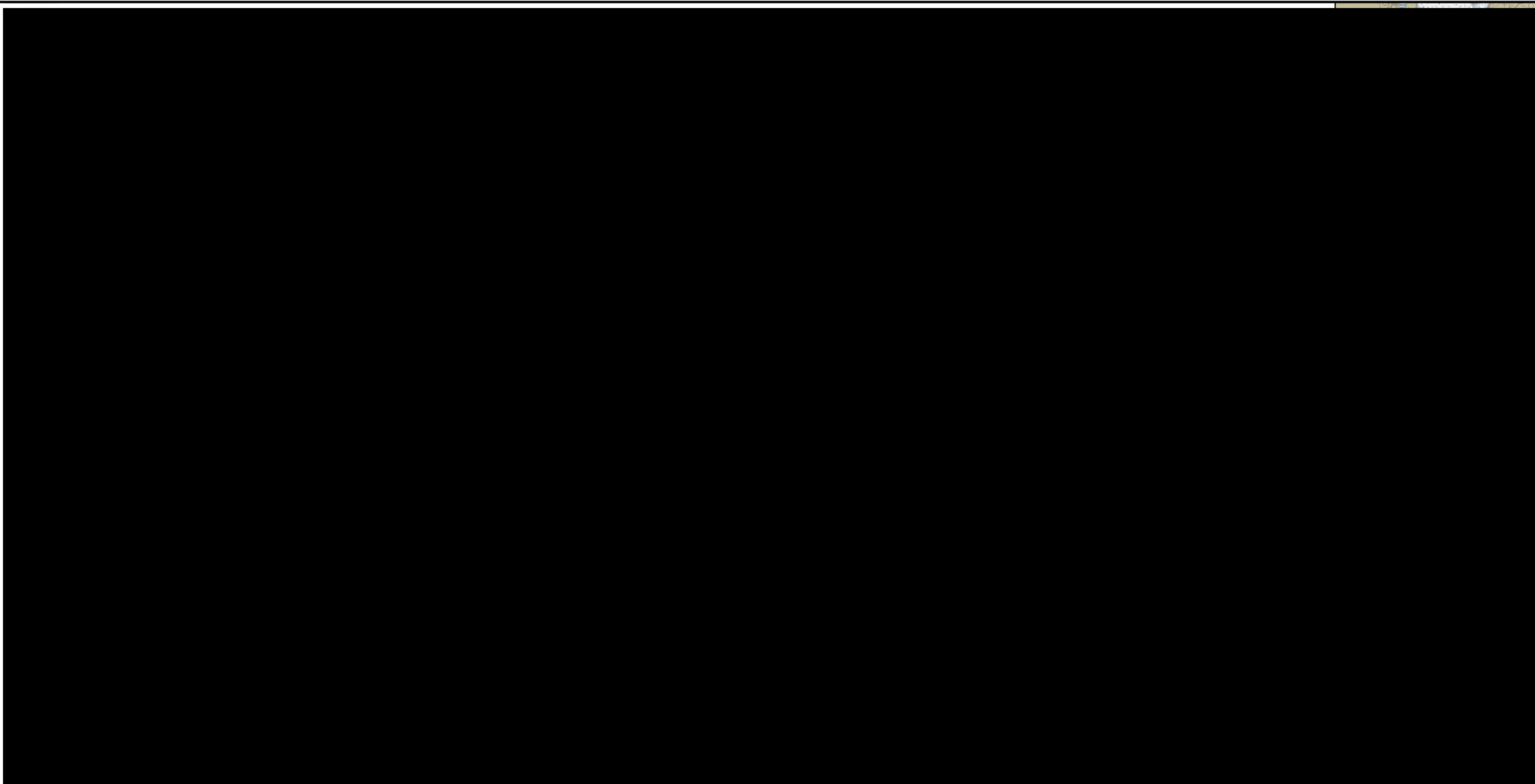

Figure 37. Representative SBP Profile in Area CM4
(0503-YT_JD129_CM400_20230509_200748_MF_CH0_LF-CH1.sgy)



Figure 38. Backscatter Mosaic for Area CM4



CM4005

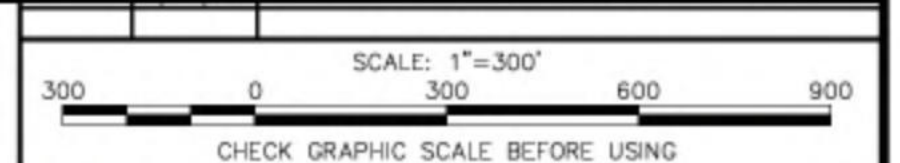

CHECK GRAPHIC SCALE BEFORE USING

PREPARED BY:
S. T. HUDSON ENGINEERS, INC.
 PROFESSIONAL ENGINEERS & CONSULTANTS
 900 DUDLEY AVE., CHERRY HILL, NJ 08002 - WWW.STHE.COM

PREPARED FOR:
 CALDWELL MARINE INTERNATIONAL
 1333 CAMPUS PKWY, SUITE 100
 WALL TOWNSHIP, NEW JERSEY 07753
 WWW.CALDWELLMARINE.COM

PLAN & PROFILE VIEW - SHEET 4

BATHYMETRIC AND GEOPHYSICAL SURVEY
 CHPE LAKE CHAMPLAIN UTILITY INVESTIGATION
 PORT DOUGLASS TO FORT MONTGOMERY, N. Y.

PROJECT MANAGER: SJM	SHEET DATE: APRIL - MAY 2023	DRAWING: 23-076-LAKE_CHAMPLAIN_CHPE-PLANING
DRAFTED BY: PAS	DRAWING DATE: JULY 7, 2023	SHEET #: 23-076 4 OF 4

ALIGNMENT DATA:

NAME	POSITIONED BY	DETECTED BY	DEP BY OF COVER (FEET)			NOTES
			WEST	CENTER	EAST	
CM4_01	MAG	MAG, SBP	8.23	8.23	8.84	DOC values may be skewed due to bathymetric slopes
CM4_02	MAG	MAG, SBP	18.85	18.37	4.76	DOC values may be skewed due to bathymetric slopes

COLOR MAPPINGS:

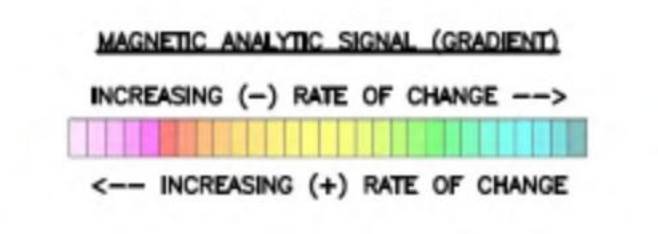
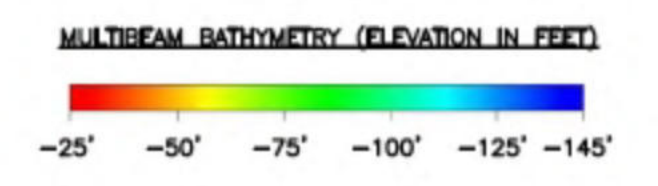

LEGEND:

- MAJOR CONTOURS (10' INTERVAL)
- MINOR CONTOURS (2' INTERVAL)
- ALIGNMENTS
- MATCHLINES
- 325 MILE POST (APPROX. STATUTE MILES)
- 1190+00 ORIGINAL CHPE STATIONING
- TP-041 ORIGINAL TURNING POINTS
- ORIGINAL ROUTE CORRIDOR
- PROPOSED NEW ROUTE
- SBP SURVEY PATH

EQUIPMENT:

TYPE	MANUFACTURER/MODEL
MAGNETOMETER/TVG	GEOMETRICS G-882 (X2)
SUB-BOTTOM PROFILER	INNOMAR MEDIUM
MULTIBEAM ECHOSOUNDER	NORBIT WINGHEAD 177H

SUB-BOTTOM PROFILE NOTES

- VERTICAL SCALE SHOWN ON SBP IMAGES INDICATES DEPTH BELOW BLANKING LINE SETTINGS AND IS NOT INDICATIVE OF RIVER BED DEPTH DISCONTINUITIES, IF ANY, ARE THE RESULTS OF THE MODIFICATION OF THESE SETTINGS DURING DATA ACQUISITION.
- SOME SBP ALIGNMENTS AND TARGETS MAY HAVE BEEN DISCERNED FROM PROFILES ADJACENT TO THE CENTERLINE PROFILES SHOWN HEREON.

ABBREVIATIONS:

- ASIG - ANALYTIC SIGNAL (MAGNETIC)
- CORS - CONTINUOUSLY OPERATING REFERENCE STATION
- CHPE - CHAMPLAIN HUDSON POWER EXPRESS
- GIS - GEOGRAPHIC INFORMATION SYSTEM
- MAG - MAGNETOMETER
- MBES - MULTIBEAM ECHOSOUNDER
- NAD - NORTH AMERICAN DATUM
- NAVD - NORTH AMERICAN VERTICAL DATUM
- NGS - NATIONAL GEODETIC SURVEY
- NOAA - NATIONAL OCEANIC AND ATMOSPHERIC ASSN.
- NSRS - NATIONAL SPATIAL REFERENCE SYSTEM
- SBP - SUB-BOTTOM PROFILER
- STHE - S. T. HUDSON ENGINEERS
- UTM - UNIVERSAL TRANSVERSE MERCATOR

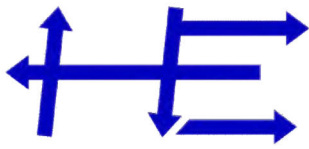

S. T. HUDSON ENGINEERS, INC.
PROFESSIONAL ENGINEERS & CONSULTANTS

CHPE Utility Investigation Mobilization Report

Survey Date:

April – May 2023

Project:

23-076

Report Status:

Rev 0

Report for:



Report Authorization and Distribution

Authored: L. Andrews, L. Quas

Approved: S. MacDonald

Date	Rev	Description
5-June-2023	0	Issued for Initial Comment

TABLE OF CONTENTS

1	Project Summary	1
1.1	Mobilization Summary	1
1.2	Personnel.....	1
1.3	Survey Equipment	2
2	Vessel Configuration, Offsets, and Interfacing	3
2.1	Offsets	4
2.2	Navigation Suite Interfacing	4
3	Geodetic Parameters	5
4	Mobilization Acceptance Tests	6
4.1	Positioning.....	6
4.1.1	GAMS Calibration	6
4.1.2	Positioning Check	8
4.2	Multibeam Echosounder	8
4.2.1	Patch Test	8
4.2.2	Draft Check.....	9
4.2.3	Sound Velocity.....	10
4.2.4	Previous Data Comparison	11
4.3	Magnetometer	12
4.3.1	Altimeter and Depth Sensor Check	12
4.3.2	Position Test and Wet Test.....	13
4.4	Sub-bottom Profiler.....	15
4.4.1	Wet Test	15
4.4.2	Positional Verification	16
4.4.3	Geological Assessment Test	17
4.4.4	Noise Test	18

List of Figures

Figure 1. M/V <i>Yeti</i>	3
Figure 2. M/V <i>Yeti</i> Survey Configuration	3
Figure 3. Online GAMS Calibration Results	7
Figure 4. Primary v. Secondary Positions at M/V <i>Yeti</i> CoG	8
Figure 5. Norbit Roll Calibration	9
Figure 6. Norbit Pitch Calibration	9
Figure 7. Norbit Heading Calibration	9
Figure 8. Screenshot of MBE Seafloor Elevation at Time of Recorded Measure Down	10
Figure 9. SVS Reading at Time of SVP Casts	10
Figure 10. MBE Profile Comparison	11
Figure 11. Geometrics G-882 Magnetometer Wrench Test	12
Figure 12. MAG Calculated Water Depth v MBE Water Depth	13
Figure 13. MAG Position Check – Grid Overview	14
Figure 14. MAG Position Check – Line 0006	14
Figure 15. MAG Position Check – Line 0007	15
Figure 16. SBP Wet Test	16
Figure 17. SBP Position Check against Magnetometer	17
Figure 18. SBP Geological Assessment	17
Figure 19. SBP Noise Test	18

List of Tables

Table 1. Hudson Project Management Team	1
Table 2. Key Field Personnel	1
Table 3. Survey Equipment	2
Table 4. QA/QC Offline Software	2
Table 5. Survey Sensor Offsets	4
Table 6. QPS Qinsy I/O	4
Table 7. Geodetic Parameters	5
Table 8. GAMS Calibration Results versus DIMCON	6
Table 9. Patch Test Results	9
Table 10. MBE Vertical Check	9
Table 11. Sound Velocity Comparison	10
Table 12. MAG Position Check	13
Table 13. SBP Position Check	16

1 Project Summary

1.1 Mobilization Summary

The following report discusses the mobilization of the M/V *Yeti* by S.T. Hudson Engineers, Inc. (Hudson) for Champlain Hudson Power Express (CHPE) as part of the development of a potential cable route between Lake Champlain and the Hudson River. The mobilization was completed prior to the project operations and included two parts: a series of alongside checks in port and calibrations performed while underway near the survey area. The alongside mobilization and checks were completed at Atlantic Highlands, NJ and Liberty Landing Marina, NJ. All mobilization activities were completed and verified by March 10, 2023.

1.2 Personnel

The following project team has been assembled and have been assigned to the roles listed below for project execution for the duration of the project phase (Table 1).

Table 1. Hudson Project Management Team

Name	Role
William Jenkins	VP of Marine Services
Steven MacDonald	Project Manager
William Busey	Technical Manager
Lawrence Andrews	Lead Technical Advisor - Survey
Scott Hiller	Geophysical Manager
Lauren Quas	Data and Reporting Manager

The following personnel were present onsite during the mobilization of the survey vessel for the project (Table 2).

Table 2. Key Field Personnel

Name	Role
Konner Williams	Party Chief
Sean Singley	Vessel Captain
Sam Bright	Surveyor
Mark Carter	Surveyor

1.3 Survey Equipment

The following survey equipment and software were used for the survey aboard the M/V *Yeti* to complete the project (Table 3 and Table 4).

Table 3. Survey Equipment

Equipment Type	Equipment Model
Primary Navigation, Motion, & Heading	Applanix POSMV OceanMaster w/RTK; Supplemented with RTK
Position Corrections	PPK from VRS Network
Secondary Positioning System	Hemisphere Atlas GNSS
Online Navigation Suite	QPS Qinsy
Multibeam Echosounder	Norbit i77h
Magnetometer	Geometrics G-882
Sub-bottom Profiler	Innomar Medium
Sound Velocity Probe	AML-3
Cable Counter	Hydrographic Consultants TCount

Table 4. QA/QC Offline Software

Software Type	Software Make/Model
Overlap Data QC and integration	Blue Marble Global Mapper
Bathymetric Data	QPS Qimera
Magnetic Data	Oasis Montaj
SBP Data	CTI SonarWiz
Post-processed GNSS	Applanix POSPac (w/ PP-RTX service)

2 Vessel Configuration, Offsets, and Interfacing

The M/V *Yeti* is a custom-built research and survey platform designed to operate in the ultra-shallow nearshore and intra-coastal environment (Figure 1). With a cruising speed of 25 knots and less than 3' draft, the vessel can access a variety of survey areas. The vessel was mobilized with the survey equipment mentioned above in the configuration shown in Figure 2.



Figure 1. M/V *Yeti*

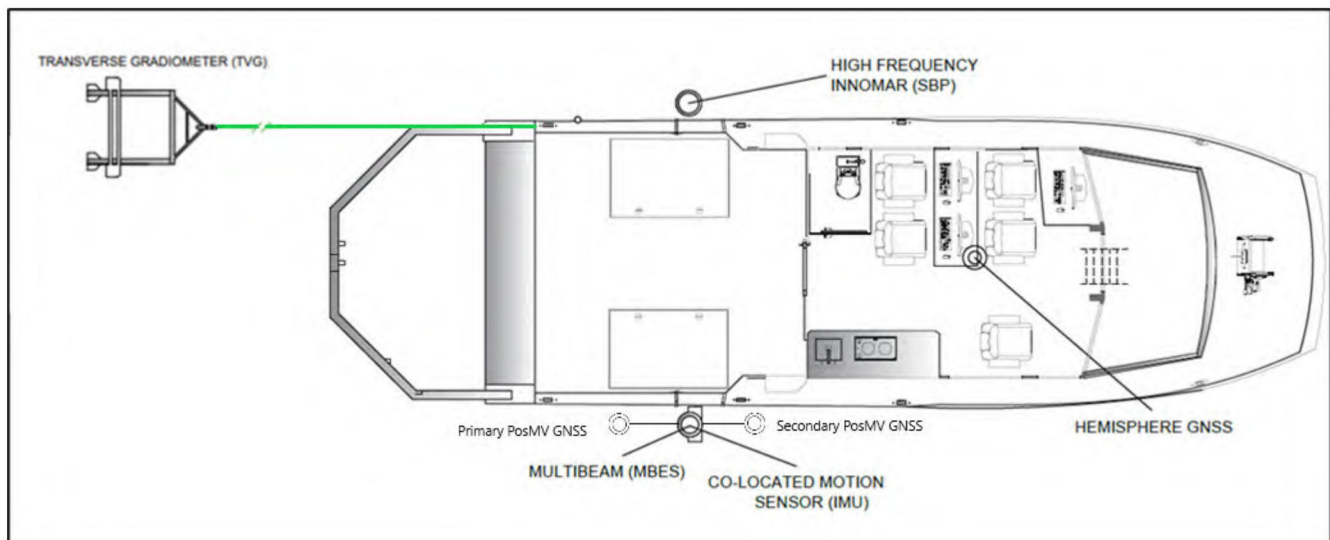

Figure 2. M/V *Yeti* Survey Configuration

2.1 Offsets

All equipment offsets were surveyed using a combination of conventional land survey techniques and ultra-high resolution 3D laser scanning. These offsets for primary equipment and vessel nodes are shown in Table 5.

Table 5. Survey Sensor Offsets

Survey Sensor Offsets			
<u>FWD</u>	<u>STBD</u>	<u>UP</u>	<u>Description</u>
0.000	0.000	0.000	Norbit MBE
0.000	0.000	0.000	Applanix POSMV Ref Pt (CRP)
0.029	0.000	0.027	Portus Pole Reference Point
-0.926	0.000	3.659	POSMV Primary Antenna
1.075	0.000	3.659	POSMV Secondary Antenna
2.602	-1.842	3.223	Hemisphere GNSS
-1.996	-3.595	-0.210	Innomar SBP
-3.964	-2.365	1.640	TVG Tow Pt

2.2 Navigation Suite Interfacing

Qinsy interfacing from the survey sensors was performed using serial and UDP connections as listed below in Table 6.

Table 6. QPS Qinsy I/O

Navigation – I/O QPS Qinsy	Settings
SBP – custom string	UDP
MAG Nav	Internal Qinsy Layback
MAG Data	9600/8/n/1
Applanix POS, HRP, HDT	UDP
MBE	UDP
ZDA PPS	UDP
GNSS Secondary	19200/8/n/1

3 Geodetic Parameters

All data were collected in NAD83 (2011) UTM Zone 18 North. Real-time Kinematic (RTK) corrections were received from the Trimble KeyNet VRS system over a cellular connection. Data were projected in UTM Zone 18 North and referenced to NAVD88 using NOAA's VDatum. Horizontal and vertical units were in US survey feet.

Table 7. Geodetic Parameters

Project Specific Geodetic Parameters	
Datum	NAD83 (North American Datum of 1983) – 2011
Ellipsoid	GRS 1980
Semi-Major Axis	a = 6878137.000 m
Semi-Minor Axis	b = 6356752.314 m
Conversion Factor to Meters	1.000000
Eccentricity	e = 0.0818191910435
Inverse Flattening	1/f = 298.257222101
Projection	Universal Transverse Mercator (North Oriented)
UTM Zone Number	18 N
Latitude of Grid Origin	0° N
Longitude of Grid Origin	75° W
False Easting (m)	500,000
False Northing (m)	0
Scale Factor at Natural Origin	0.9996
Vertical Datum	North American Vertical Datum of 1988 (NAVD88)

Offshore satellite based corrected GNSS systems operating in ITRF14 were transformed to real time coordinates in NAD83 (2011) in Qinsy. The transformation was time-dependent for the current date of collection.

4 Mobilization Acceptance Tests

The dockside and sea-trial acceptance tests were completed in accordance with industry best practices, manufacturers' recommendations, and Hudson's standard operating procedures.

4.1 Positioning

Primary navigation for the project was provided by the Applanix POSMV OceanMaster system (integrated into the Norbit MBE head) supplemented with PPK from the VRS network.

4.1.1 GAMS Calibration

The GAMS Calibration was completed three (3) times to ensure no bias or offset errors in the system (Table 8).

Table 8. GAMS Calibration Results versus DIMCON

GAMS Calibration		
	<u>STBD</u>	<u>UP</u>
DIMCON	0.000	2.000
GAMS 1	0.010	2.000
GAMS 2	0.010	2.010
GAMS 3	0.030	2.010
GAMS AVG	0.015	2.006
DELTA	0.015	0.006

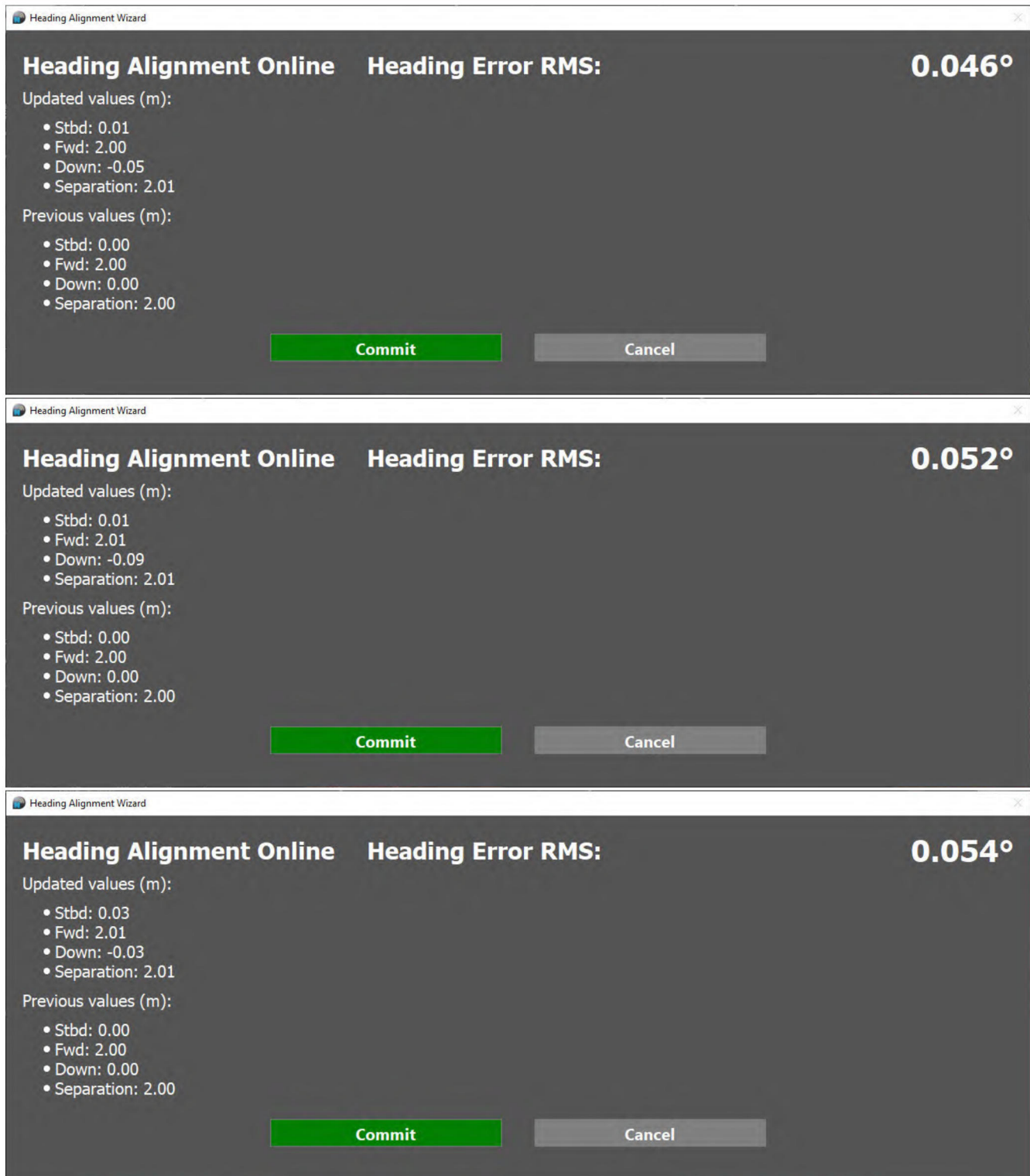

Figure 3. Online GAMS Calibration Results

4.1.2 Positioning Check

While at dock, data were recorded in QPS Qinsy at the M/V *Yeti* CoG output point using both the POSMV and the Hemisphere Atlas GNSS. Results are shown in Figure 4.

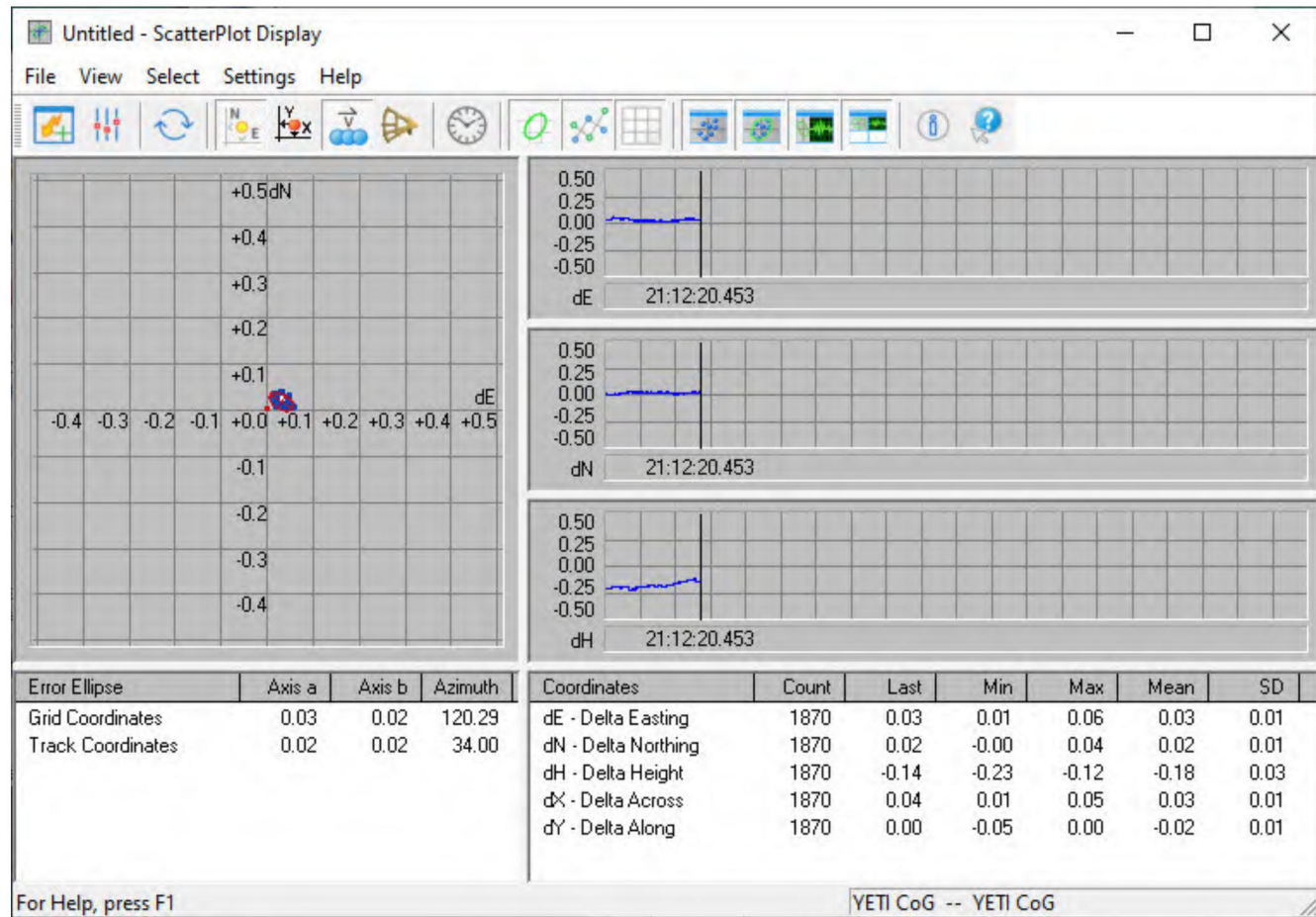

Figure 4. Primary v. Secondary Positions at M/V *Yeti* CoG

4.2 Multibeam Echosounder

The installed multibeam echosounder (MBE) on the vessel was a Norbit i77h (narrow 0.5° @ 400kHz) with fully integrated Applanix POSMV.

4.2.1 Patch Test

A patch test was performed on the M/V *Yeti* MBE system at a known location near the survey area. Two lead processors performed the patch test calibration in QPS Qimera; results showed good alignment between the two sets of results and were then averaged for final application in Qinsy. Table 9 shows the final patch values applied for the project. The integrated MBE/IMU were factory aligned and therefore required very little angular alignment.

Figure 5, Figure 6, and Figure 7 show the cross sections of the patch test results.

Table 9. Patch Test Results

Roll	Pitch	Yaw	Time Delay
-0.103°	0.176°	-0.04°	0.00s

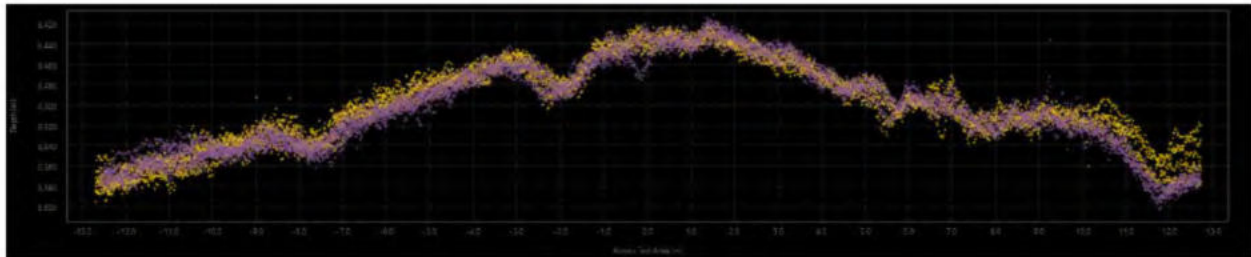

Figure 5. Norbit Roll Calibration

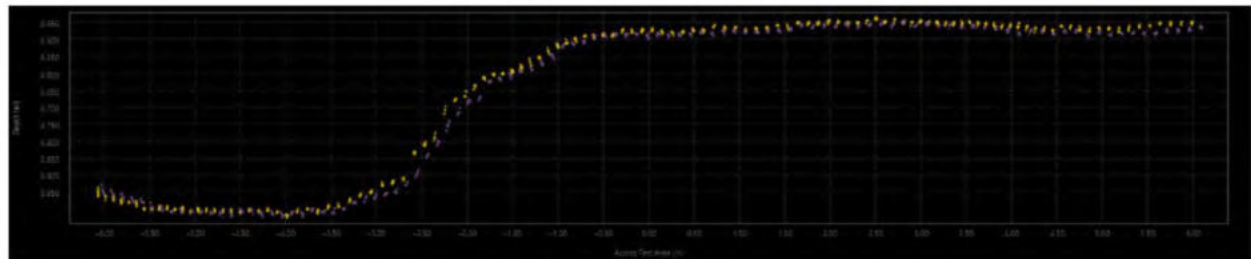

Figure 6. Norbit Pitch Calibration

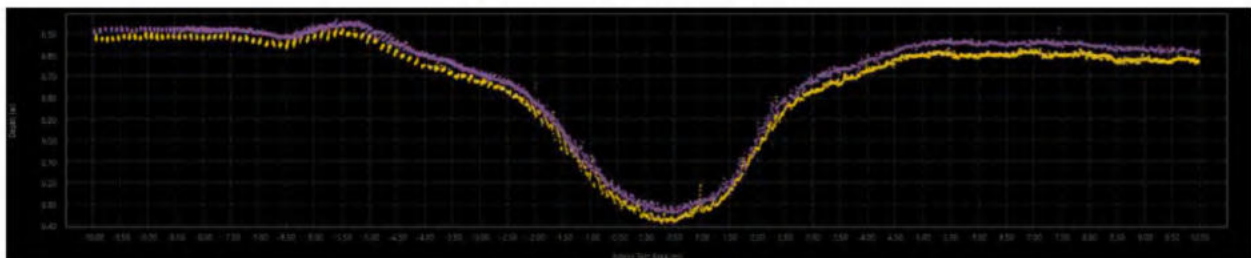

Figure 7. Norbit Heading Calibration

4.2.2 Draft Check

Alongside the dock, the MBE system was lowered into the water and data were recorded while simultaneously performing a measure down from a known point to the seafloor adjacent to the MBE. The data were used to determine an independent sounding to compare with real-time seafloor elevations (Table 10 and Figure 8).

Table 10. MBE Vertical Check

MBE Vertical Check	
Measurement	Meters
Measure Down Point to Seabed	4.981
MBE Seafloor Elevation	3.290
Measure Down Point to MBE Head	1.634
Computed Seafloor Elevation	4.924
Delta	-0.057

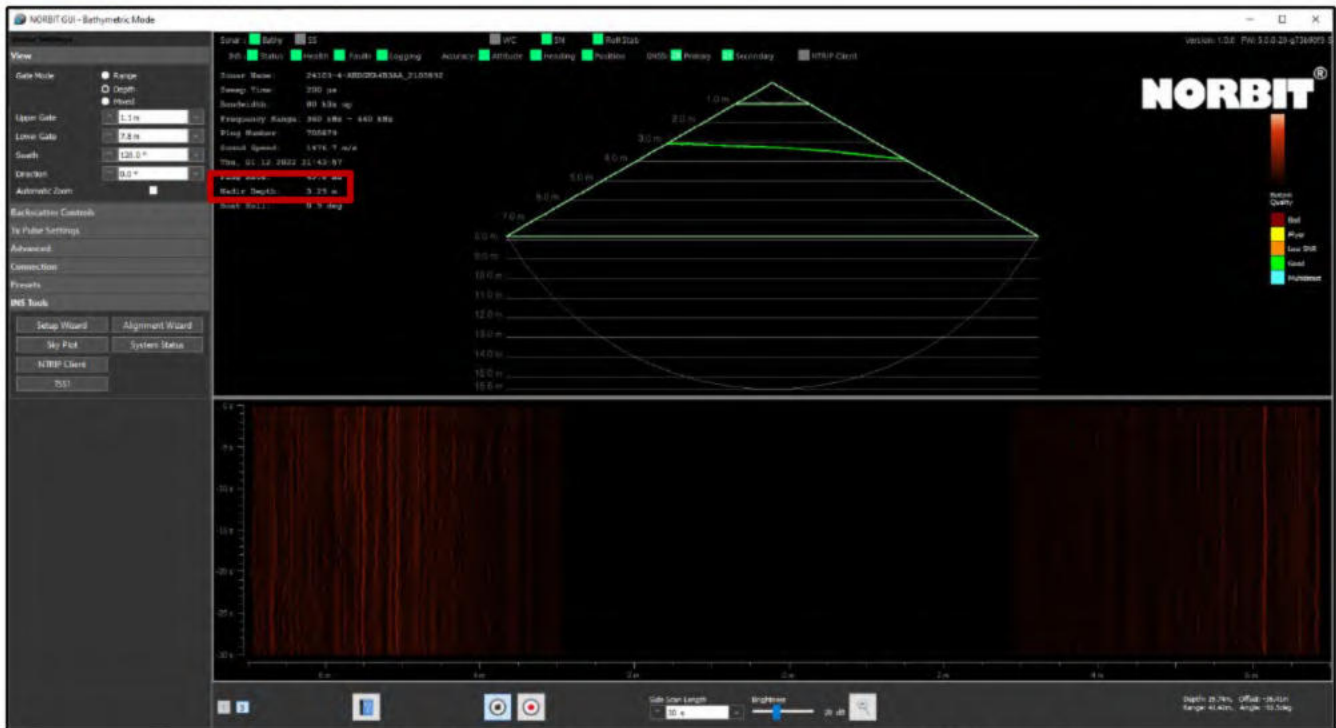

Figure 8. Screenshot of MBE Seafloor Elevation at Time of Recorded Measure Down

4.2.3 Sound Velocity

The AML-3 Sound Velocity Probe (SVP) was lowered near the Norbit MBE system alongside dock and recovered to the surface. The value of the SVP was compared to the reading from the AML SVS installed on the MBE system (Table 11).

Table 11. Sound Velocity Comparison
Sound Velocity Comparison

System	Reading at ~1m
AML-3 SVP	1446.06 m/s
AML SVS (installed on MBE)	1445.90 m/s
Delta	0.16 m/s

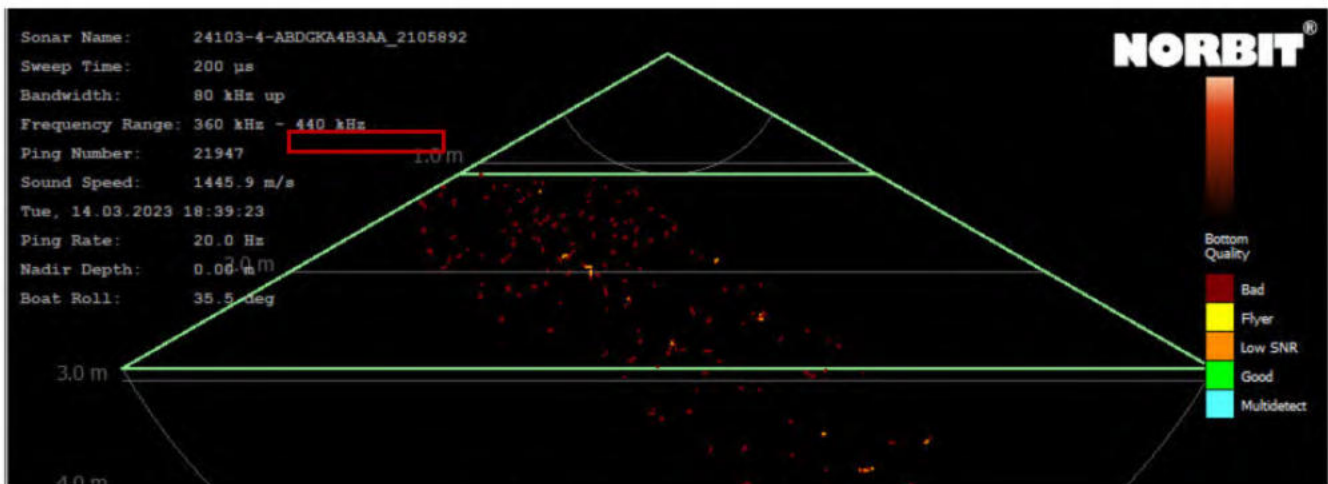

Figure 9. SVS Reading at Time of SVP Casts

4.2.4 Previous Data Comparison

Patch Test data were acquired over a known discrete feature provided by the client. Horizontal and vertical comparisons were made of the M/V *Yeti* data against the provided dataset with acceptable results.

Figure 10 shows the profile over the discrete feature, showing zero horizontal offset and an average vertical offset of less than 0.041m.



Figure 10. MBE Profile Comparison

4.3 Magnetometer

Two Geometrics' G-822 cesium vapor marine magnetometers in a Transverse Gradiometer (TVG) frame were utilized for the duration of the survey. A wrench test was performed to ensure the magnetometer was in proper working order on deck (Figure 11).

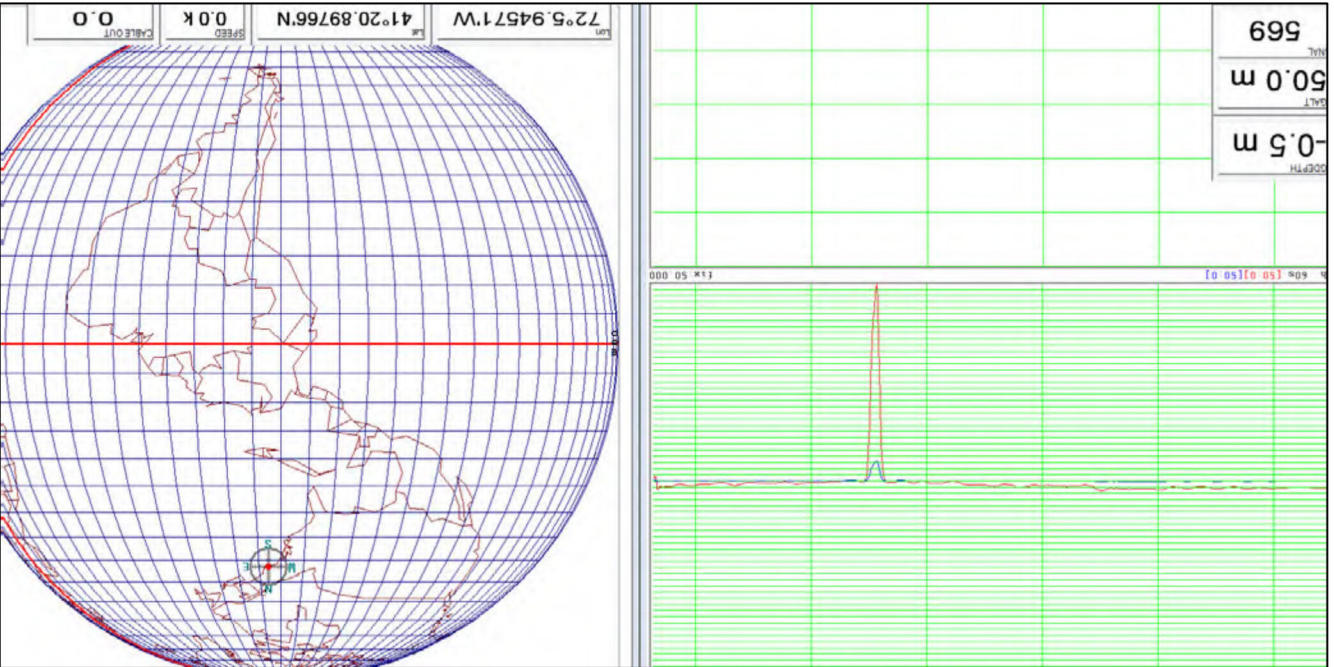

Figure 11. Geometrics G-882 Magnetometer Wrench Test

4.3.1 Altimeter and Depth Sensor Check

During magnetometer wet testing, the TVG was flown at approximately 4.5 m altitude down a shallow slope. The total water depth was recorded along with the MAG depth and altitude. The MAG depth and altitude were combined to compare against the total water depth (Figure 17).

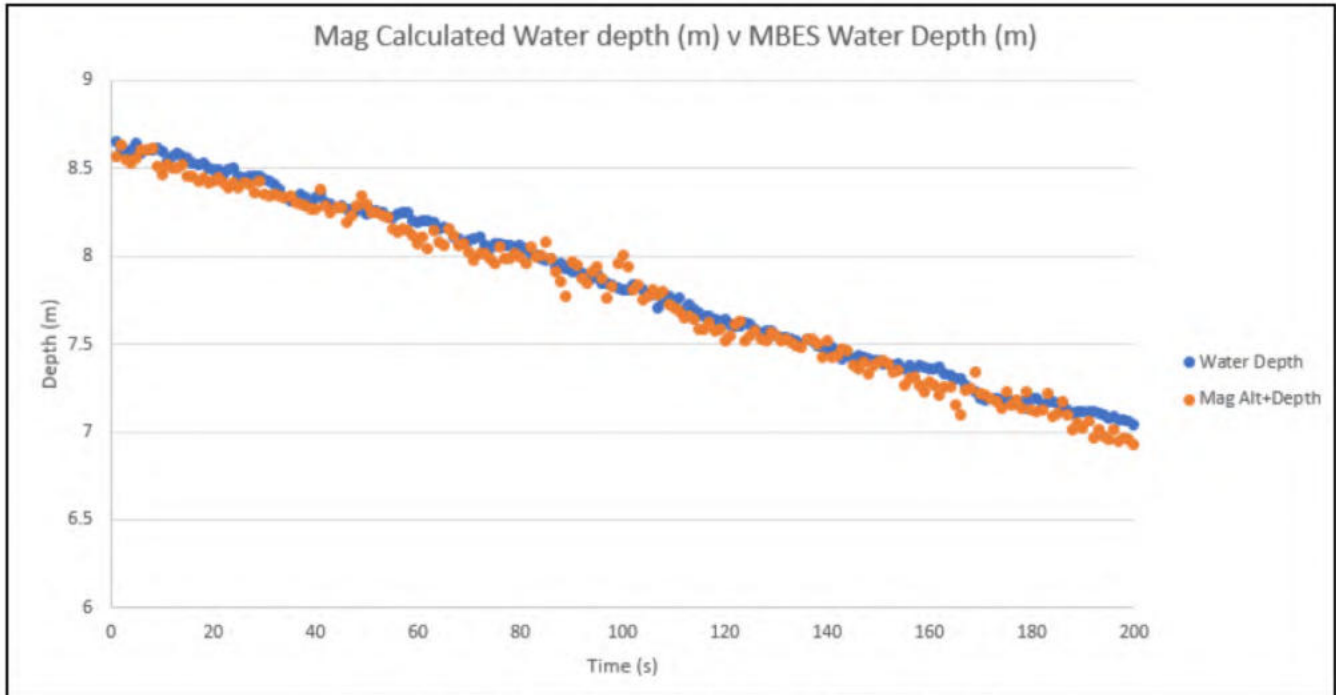

Figure 12. MAG Calculated Water Depth v MBE Water Depth

4.3.2 Position Test and Wet Test

At the calibration site near the survey area, the TVG was deployed, and a wet test completed while underway. Several reciprocal passes were made with the TVG over a strong linear anomaly. Data were logged while underway for five minutes prior to starting position check lines. Comparison of the anomaly center point positions are shown in Table 12. Anomaly alignment was offset due to the physical magnetometer offset during the trial.

Table 12. MAG Position Check

MAG Position Check						
Target	Line 0006 X	Line 0006 Y	Line 0007 X	Line 0007 Y	Delta X (m)	Delta Y (m)
1	580918.26	4497126.57	580922.81	4497128.01	-4.55	-1.43

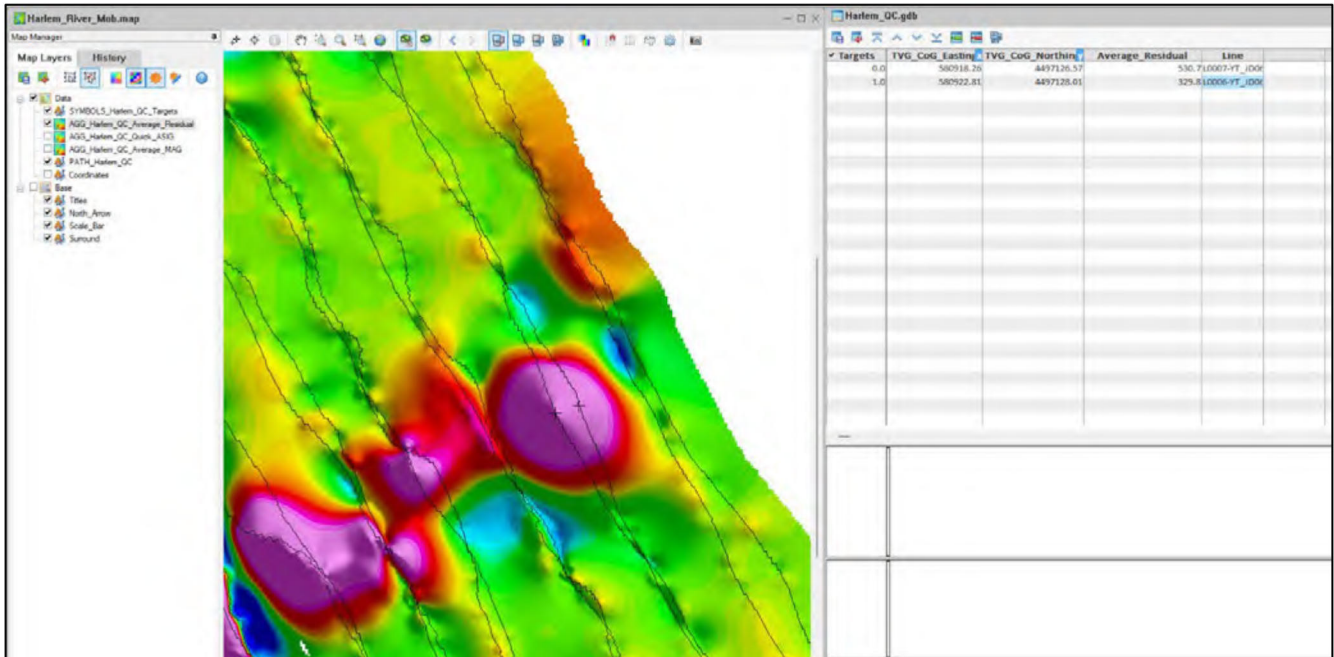

Figure 13. MAG Position Check – Grid Overview

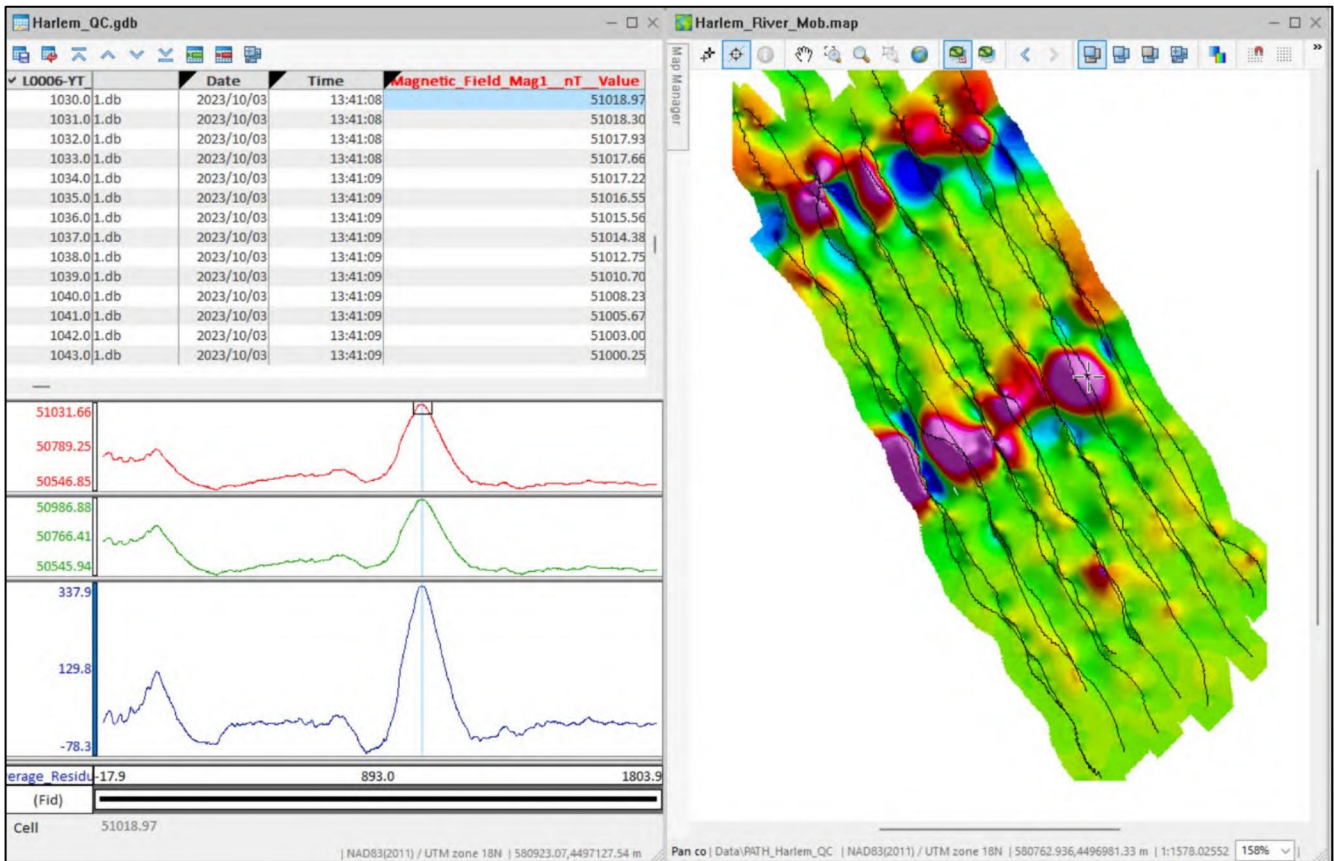

Figure 14. MAG Position Check – Line 0006

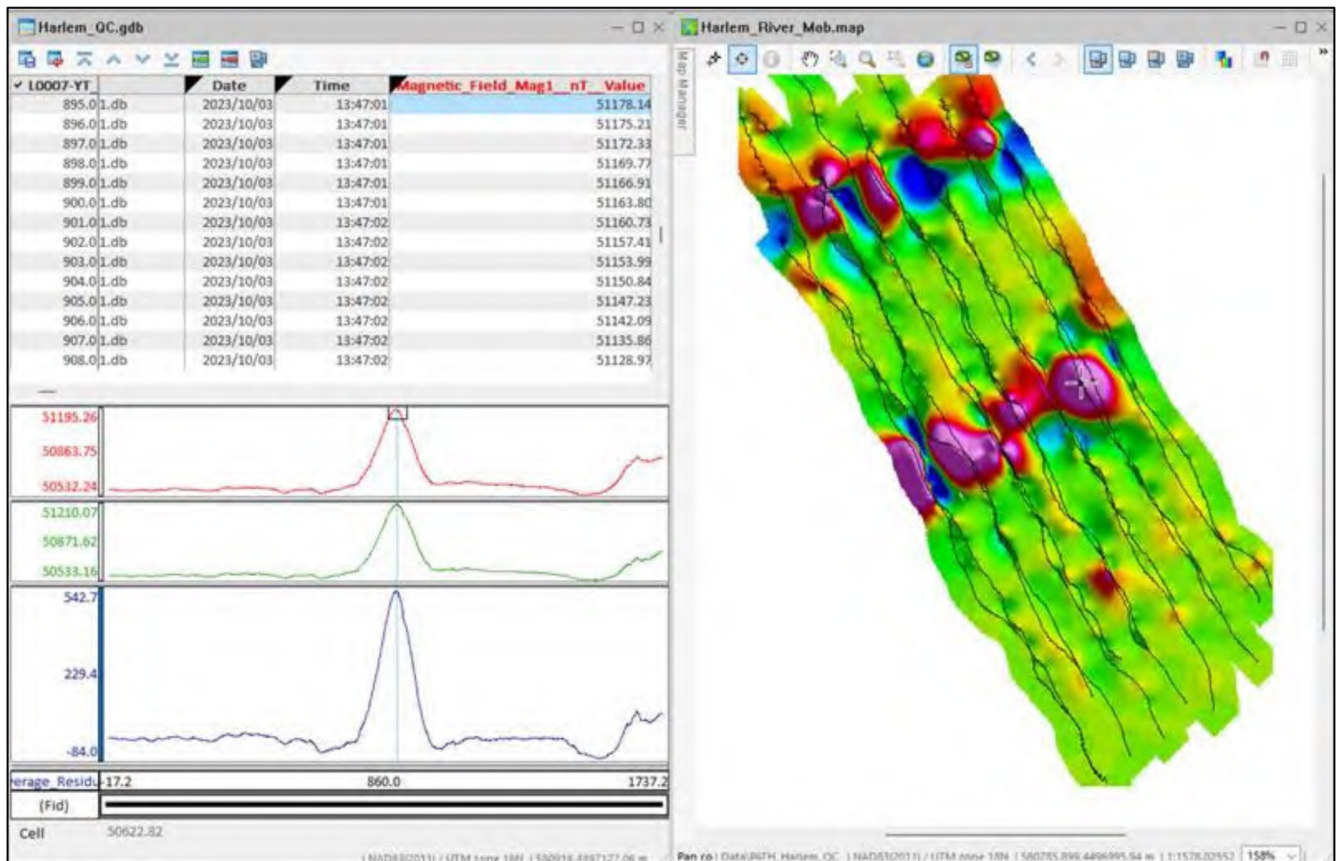

Figure 15. MAG Position Check – Line 0007

4.4 Sub-bottom Profiler

An Innomar Medium was utilized on the project as the sub-bottom profiler and was pole mounted to the port side gunwale of the vessel.

4.4.1 Wet Test

Data were acquired at survey specifications to ensure that data, time, heave, and navigation were received and logged properly (Figure 16).