

**APPENDIX P:  
CORROSIVE EFFECTS STUDY  
(CC 162B)  
CASE 10-T-0139**



CHPE LLC

---

# UNDERGROUND DC CABLES

Potential Effects of Underground DC Cables  
on Co-Located Infrastructure





## CHPE LLC

---

# Potential Effects of Underground DC Cables on Co-Located Infrastructure

*Note: While this analysis was performed specifically for the assets noted in design packages 1A and 1B, the results in this report are applicable for other design packages, segments and utilities.*

**PROJECT NO. 70082351**

**OUR REF. NO. 70082351-TN-002**

**DATE: May 2022**

WSP

Amber Court

William Armstrong Drive

Newcastle upon Tyne

NE4 7YQ

Phone: +44 191 226 2000

Fax: +44 191 226 2104

WSP.com

---



# QUALITY CONTROL

---

<b>Issue/revision</b>	<b>First Issue</b>	<b>Second Issue</b>	<b>Third Issue</b>
Remarks	First Issue	Second Issue	Third Issue
Date	25/05/2022	27/05/2022	28/06/2022
Prepared by	<b>Lee Martin</b>	<b>Lee Martin</b>	<b>Lee Martin</b>
Signature			
Checked by	<b>Paul Hudson</b>	<b>Paul Hudson</b>	<b>David Dilworth</b>
Signature			
Authorized by	<b>Alex Scott</b>	<b>David Dilworth</b>	<b>Alex Scott</b>
Signature			
Project number	70082351	70082351	70082351
Report number	70082351-TN-002	70082351-TN-002	70082351-TN-002
File reference	70082351-TN-002	70082351-TN-002	70082351-TN-002
Note: Text charges to clarify document covers entire CHPE project made 18/11/2022.			



# CONTENTS

---

<b>1</b>	<b>INTRODUCTION AND EXECUTIVE SUMMARY</b>	<b>2</b>
<b>2</b>	<b>REFERENCED DOCUMENTS</b>	<b>4</b>
<b>3</b>	<b>POTENTIAL EFFECTS OF UNDERGROUND DC CABLES ON CO-LOCATED INFRASTRUCTURES</b>	<b>5</b>
<b>3.1</b>	<b>HVDC TECHNOLOGY</b>	<b>5</b>
<b>3.2</b>	<b>HVDC TOPOLOGY</b>	<b>6</b>
<b>3.3</b>	<b>DC CABLE EFFECTS ON CO-LOCATED INFRASTRUCTURE</b>	<b>7</b>
3.3.1.	ELECTRIC FIELDS	7
3.3.2.	MAGNETIC FIELDS	7
3.3.3.	INDUCED VOLTAGES	9
3.3.4.	HVDC CABLE	10
3.3.5.	INDICATIVE STUDIES	11
3.3.6.	INTERACTION WITH UTILITIES	12
3.3.7.	CORROSION EFFECTS	14
3.3.8.	TRANSIENT FAULT CONDITIONS	14
	<b>APPENDIX A – UTILITIES INTERACTION</b>	<b>16</b>

---



# 1 INTRODUCTION AND EXECUTIVE SUMMARY

---

## 1.1 INTRODUCTION

The Champlain Hudson Power Express (CHPE) project will deliver 1250MW of renewable power from Hydro-Quebec TransEnergie's Hertel substation near La Prairie Quebec to NYPA's Astoria Annex 345kV substation located in the Astoria neighbourhood in the New York City borough of Queens.

The HVDC transmission system comprises two symmetrical monopole HVDC voltage source converter stations at either end of the link and a HVDC cable circuit, comprising two, +/-400kV DC cables.

The HVDC cable route within the United States will comprise of approximately 193 miles of submarine cable route and approximately 147 miles of land cable route.

The HVDC underground cable system will be installed within existing town and state roadway and railroad rights of way (ROW). The two cables will be installed side by side in ducts buried in a trench or by horizontal directional drill (HDD).

Along the route there are multiple utility services and infrastructure co-located in the same ROW.

The objective of this report is to assess the interaction of the HVDC cable system on this co-located infrastructure (CI) for the project.

## 1.2 EXECUTIVE SUMMARY

The selection of the topology and design of the CHPE interconnector and the associated configuration of the underground DC cables, have been taken into account when assessing the potential interference effects on other co-located utility services. The effects considered are:

- Electric fields
- Magnetic fields
- Induced voltages
- Corrosion effects
- Transient Fault Conditions

indicative studies have been carried out and these studies indicate that the proposed HVDC cable system will have no adverse effect on any co-located utility services or infrastructure with regard to electric and magnetic fields, induced voltages, corrosion and transient fault conditions.

Further investigation may be required should the telecommunication services, identified as being co-located, utilize copper core cables to assess if there is the potential for signal interference from the HVDC cable system. Such studies can only be done following the completion of the detailed designs for the overall system by the converter and cable system suppliers.

The study findings are currently applicable for the entire project. It may be determined in the future that exceptional circumstances for a particular or newly discovered CI warrant a further targeted study which can be evaluated at that time.



To support this a sample calculation has been carried out (section 3.3.6.4) relevant to any CI running parallel to the HVDC cable system which shows that the induced voltage will be approximately 463mV/mile. The induced voltage limit for power cables is typically of the order of 65V. A parallel run of 134miles would be required before this limit was reached.



## 2 REFERENCED DOCUMENTS

---

Document Number	Document Title
Drawing No. G-000 Rev A	CHPE Package 1A – Putnam to Dresden Cover Sheet
Drawing No. G-002 Rev A	CHPE Package 1A – Putnam to Dresden Survey Notes and Legend
Drawing No. C-101 Rev A	CHPE Package 1A – Putnam to Dresden STA. 10000+00 to STA. 10015+00
Drawing No. C-621 Rev A	CHPE Package 1A – Putnam to Dresden Trenching Details
Drawing No. C-901 Rev A	CHPE Package 1A – Putnam to Dresden Utility Typical Separation Details
IEC 60287-1-1	Electric cables- Calculation of current rating – Part 1: Current rating equations (100% load factor) and calculation of losses
Cigre TB 283	Special Bonding of High Voltage Power Cables
Document 1AA0518810 Rev A.	CHPE A1 – Technical Proposal Land Cable





### **3 POTENTIAL EFFECTS OF UNDERGROUND DC CABLES ON CO-LOCATED INFRASTRUCTURES**

---

#### **3.1 HVDC TECHNOLOGY**

The CHPE Interconnector will use the latest HVDC technology, known as Voltage Source Converter (VSC). This has now become the dominant technology used for HVDC interconnectors as it provides additional functionality when compared with the earlier generation of Line Commutated Converters (LCC).

The VSC is designed as a Modular Multi-level Converter (MMC) in which the DC capacitor, which maintains the DC voltage, is segmented into many small units each of which is switched in and out by a semi-conductor switching device. The voltage on each DC capacitor is about 2 kV. By progressively switching in and out steps of DC voltage in the correct sequence a stepped voltage waveform can be generated which, with many hundreds of steps, becomes a good approximation to an AC sinusoidal waveform. The quality of this voltage waveform may be sufficient that AC side harmonic filters are not required.

On the DC side of the converter, the “ripple” voltage generated by the switching action, i.e. AC harmonic distortion, which is superimposed on the DC voltage will induce voltages in adjacent metallic services and infrastructure and has the potential for interference with telecommunication systems. The spectrum of harmonic currents flowing in the DC cable loop that are the source of any interference issues is from 100 Hz to 5000 Hz.

The design of the modern VSC scheme used by CHPE inherently requires no, or only very small, harmonic filters at the AC terminal to achieve compliance with the standards for acceptable distortion levels in the AC transmission network (in comparison to LCC technology and earlier generations of VSC schemes, which required larger harmonic filters). Similarly, no harmonic filters are normally required at the DC terminal to avoid interference to adjacent telecommunication circuits from the HVDC cable circuit.

### 3.2 HVDC TOPOLOGY

The chosen circuit topology for CHPE HVDC interconnector is a Symmetrical Monopole.

This topology consists of a single AC to DC converter at each end of the link connected by 2 DC cables, one positive and one negative. There is no neutral or ground point on the DC side of the circuit. A simplified diagram of the symmetrical monopole topology is shown in **Figure 1**.

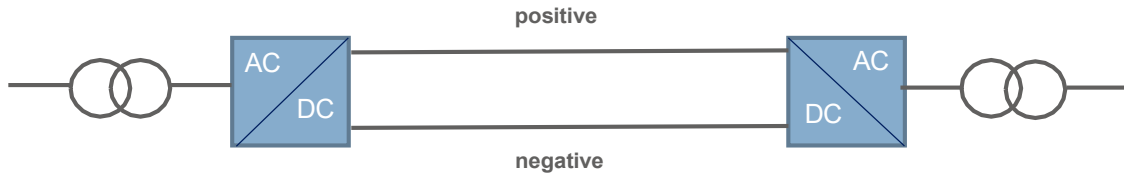

**Figure 1 – Symmetrical Monopole Topology**

The DC current in the submarine and underground cables flows in the loop between the positive and negative cables and between the two converter stations. In operation there is no path for DC current outside of this loop, thus there can be no DC current flowing in the water or the ground.

In the event of a fault on the AC or DC systems of the interconnector, automatic protection systems will disconnect the complete scheme by opening circuit breakers at the Grid connection points in less than 0.1 seconds. A fault in a land (or submarine) cable would occur between the central high voltage core and the outer sheath, which is connected to ground potential. Thus, no fault current can escape from the cable into the ground.



### 3.3 DC CABLE EFFECTS ON CO-LOCATED INFRASTRUCTURE

The selection of the topology and design of the CHPE interconnector, and the associated configuration of the underground DC cables, have been taken into account when assessing the potential interference effects on other co-located utility services. The effects considered in the following sections are:

- Electric fields
- Magnetic fields
- Induced voltages
- Corrosion effects
- Transient Fault Conditions

The term Electromagnetic Field (EMF) is the name given when considering both electric and magnetic fields.

Indicative studies have been carried out and these studies indicate that the HVDC cable system will have no adverse effects on any co-located infrastructure. However, it should be noted that a detailed study requires detailed design of the DC cable system to determine the harmonic distortion generated at the DC terminals of the converter stations and a detailed model of the submarine and underground cables. Both models will only be available after the suppliers selected to construct the converter stations and DC cable system have completed detailed designs.

The results of the indicative studies of the design of the CHPE interconnector are summarized in section 3.3.5 below.

#### 3.3.1. Electric Fields

This is the electric field which exists between any conductor at high voltage and earth.

For the CHPE DC cable system, each cable is enclosed within an earthed metallic sheath. Therefore, there is no electric field external to the cable.

#### 3.3.2. Magnetic Fields

The DC cables will generate a magnetic field. This magnetic field will be composed of two types of field: -

- a static field associated with the DC current in the cable conductor
- a field that varies over time as the AC current in the cable conductor varies with time.

The AC current is the result of unwanted “ripple currents” due to the converter not perfectly converting AC current to DC current, and they are significantly less than the DC current. However, the cable sheath will be earthed at both ends of the cable route and any AC current in the conductor will induce a current in the opposite direction in the cable sheath, thereby reducing the overall magnetic field of the cable.

The static field associated with the DC current will interact with the earth’s magnetic field causing a localized increase or decrease in field strength which will decay rapidly as the distance from the center



line of the cable increases. For context, the geomagnetic field varies throughout the Earth from 25 to 65 $\mu$ T. In the New York area, the Earth's magnetic field is approximately 50 $\mu$ T.

A preliminary calculation of the potential magnetic field generated by the DC cables is given below:

## 1. Static Field

The DC current of 1638A flowing in the DC cables will generate a static magnetic field of approximately 36 $\mu$ T directly above the trench, 3' above ground level. This field strength decreases rapidly with distance away from the cables, at 10' from the center of the trench the field is approximately 13 $\mu$ T and at 20' the field is approximately 5 $\mu$ T. These figures can be compared to the earth's natural magnetic field, which is in the region of 50 $\mu$ T at the latitude of New York. The stray magnetic field may add to (e.g. 63 $\mu$ T at 10' distance) or subtract from (e.g. 37 $\mu$ T at 10' distance) the natural background field. These are very small changes in the DC magnetic field environment

Static magnetic fields of this magnitude will have no effect on any service or infrastructure, whether metallic or otherwise.

## 2. Time Varying Field

The field strength is a function of the superimposed AC harmonics, or "ripple", present on the cable system due to the conversion effects from AC to DC. This "ripple" is approximately 1-2% of the DC system voltage, giving a magnitude of the order of 4-8kV.

The field strength is impacted by 2 factors:

1. The induced sheath current (which is in opposite direction to the current in the cable conductor) so the overall effect is the conductor current minus the sheath current. The amount of circulating current will depend on the electrical resistance of the sheath (lower resistance gives higher circulating current) and spacing of cables (greater spacing gives higher circulating currents).
2. The spacing between the conductors, as the current in each cable is in opposite directions so will tend to cancel each other out. The closer the cables are together, the better the cancelling out and the less the magnetic field produced.

The DC cable system is bonded to earth along the cable route and as such the ripple current will induce a circulating current in the metallic sheath of the cable. The magnitude of the circulating current is dependent upon the spacing of the DC cables (it increases as the spacing increases) and being in opposite direction to the primary current has a cancelling effect on any time varying field (EMF) generated by the DC cable system.

### 3.3.3. Induced Voltages

#### General

The induced voltage which can cause currents to flow in metallic services and cause interference to telecommunications signals is the result of the power cable generating a magnetic field that then interacts with the utility service, as illustrated in **Figure 2**.

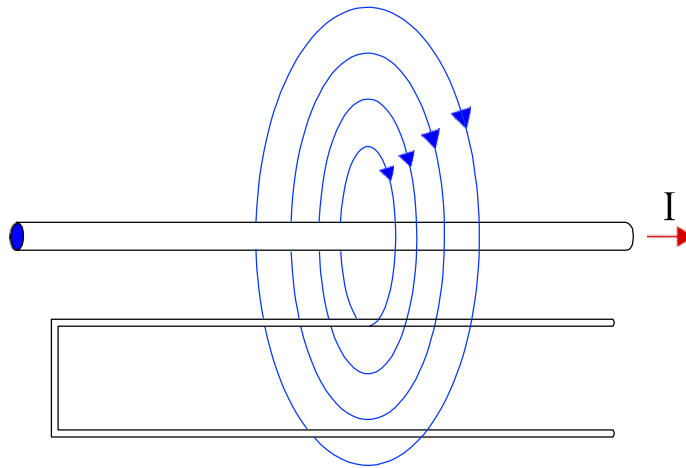
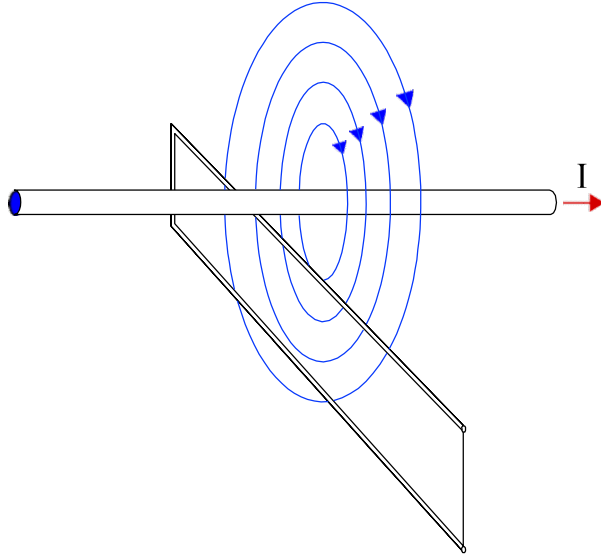

**Figure 2 – DC cable with utility service running in parallel**

The blue lines shown magnetic flux which is generated by the DC cable carrying the current  $I$ . If the current  $I$  changes over time, for example if the current is alternating current (AC), the magnetic flux will change over time.

Faraday's Law states that the electromotive force around a closed path is equal to the negative of the time rate of change of magnetic flux enclosed by the path. A metallic utility service with the go and return path is shown below the DC cable. The loop encloses some magnetic flux so an electromotive force will be generated by any changes in the magnetic flux, leading to induced voltage or current. It should be noted that the amount of flux linkage will be increased as the length of the telecom/signal cable parallel to the power circuit increases, hence the voltage generated is proportional to the length the telecom/signal cable that runs in parallel to the power circuit.

**Figure 3** shows the concept of the utility service crossing the DC cable at right angles.



**Figure 3 – DC cable with telecom/signal cable crossing at right angles**

The magnetic flux no longer goes through the loop formed by the utility service go and return path, so no magnetic flux is enclosed by the utility service and no electromotive force is generated. Therefore, if the DC cable crosses the utility service at right-angles, and not run in parallel, then there will be no induced voltage or any signal interference.

### 3.3.4. HVDC Cable

The major component of the current in the cables is DC, which generates a magnetic field that is not time varying and therefore cannot cause an induced voltage into co-located utility services. Hence, the only concern relates to the superimposed AC harmonic currents which are driven around the cable loop by the harmonic voltages generated by the AC/DC converters at each end of the interconnector. These harmonic voltages are of a magnitude of approximately 1-2% of the system voltage.

The time varying magnetic field associated with the AC ripple currents can interact with co-located metallic utility services and cause induced voltages and currents in these services. This effect does not exist when a utility service is crossed at  $90^\circ$  and increases to a maximum when a utility service runs in parallel to the cable. The effect is a function of the magnitude of the AC current flowing in the cable circuit, the frequency, the length the utility services running in parallel, the separation distance between the utility service and the cable, and any other parallel conductors that have currents inducted by the DC cable.

As noted previously, a detailed study requires detailed design of the converter system to determine the harmonic distortion generated at the DC terminals of the converter stations and a detailed model of the submarine and underground cables. Both models will only be available after the suppliers selected to construct the converter stations and DC cable system have completed detailed designs under the Engineering, Procurement and Construction contracts (EPC contracts).



### 3.3.5. Indicative Studies

indicative studies have been carried out, using the established formulae for calculating induced voltages, and these studies indicate that the proposed HVDC cable system will have no adverse effects on any co-located utility services.

Details of the formulae and parameters used are given below with the results being listed in Appendix A, Table 1 and each of the following sections.

#### Formula:

The induced voltage is derived from the following series of formulae: -

The reactance per unit length of sheath per unit length

$$X = 2\pi 10^{-7} \ln\left(\frac{2s}{d}\right) \quad \Omega/\text{m} \quad (\text{see IEC 60287-1-1 Section 2.3.1})$$

Where:

- $\omega$  =  $2\pi$  frequency (1/s)
- S = axial spacing between cables (mm)
- d = mean diameter of sheath (mm)

The current in the sheath induced by the current in the conductor

$$I_s = \frac{I}{\sqrt{1 + \left(\frac{R_s}{X}\right)^2}} \quad \Omega/\text{m} \quad (\text{see IEC 60287-1-1 Section 2.3.1})$$

Where:

- I = current in conductor (A)
- R<sub>s</sub> = the sheath resistance ( $\Omega$ )

The reactance per unit length between the DC cables (cable m and cable n) and the parallel conductor (p) per unit length

$$X_{mnp} = 2\pi 10^{-7} \ln\left(\frac{d_{mp}}{d_{np}}\right) \quad \Omega/\text{m} \quad (\text{derived from Cigre TB 283 equation A6})$$

Where:

- d<sub>mp</sub> = distance between DC cable m and parallel conductor p
- d<sub>np</sub> = distance between DC cable n and parallel conductor p

Induced voltage on parallel conductor is

$$V = (I - I_s) X_{mnp} \quad \text{V/m}$$



### Data Input Parameters:

Harmonic current (I) 1 – 2% of rated current (1638A) – 32.76A – selected as the upper limit of the expected value (2%).

Frequency – 60Hz

Cable spacing – 550mm (1' 10") (S) – selected to represent the typical trench section detailed in Kiewit drawing C-621.

Cable dimensions and resistances ( $d, R_s$ ) – selected from NKT design information provided in document 1AA0518810 Rev A.

Spacing to service and length of parallel run ( $d_{mp}, d_{np}$ ) – based on proposed route corridor and received information about service locations. The calculations for underground utilities are based on the minimum separations given in Kiewit drawing C-901 Rev A. For overhead utilities a separation of 16'5" (5m) is assumed unless stated otherwise. The length of parallel run for each utility is taken from Kiewit drawing C-101 Rev A.

Notes :-

- Calculations are based on the fundamental frequency (60Hz), rather than a spectrum of smaller components at different frequencies. As mentioned previously this report gives an approximation, possibly worst case, of the induced voltages. Detailed studies only being possible after the completion of the converter and cable systems detailed designs by the contractors.
- Utilities crossing the HVDC cable system do so at varying angles. If the angle of crossing is  $90^\circ$  there can be no induced voltages as noted before. As the angle varies from  $90^\circ$  the induced voltage increases to a maximum when the angle is  $0^\circ$  (that is the service is in parallel). For simplification the induced voltage for all crossings has been calculated as if the utility is in parallel unless very close to  $90^\circ$ . The results are, therefore, higher than will be the case, however the results are so low that the additional complication of carrying out a calculation for the actual angle of crossing is considered unnecessary.

### 3.3.6. Interaction With Utilities

The induced voltage for the 14 identified utilities in Package 1A have been considered in line with the above methodology for example purposes. The results being worse case. See Appendix A, Table 1.

In all but three cases the induced voltage calculated are  $\leq 15\text{mV}$ . The three utilities above this value are Verizon telecommunication services with calculated induced voltages of 43mV, 63mV and 59mV. Two of these are identified as fiber optic cables and induced voltages will have no effect on the transmitted telecommunication signal. The third is not clearly identified as fiber or copper and may require further detailed analysis should it be copper rather than fiber.

Each of the types of utility are discussed in more detail below.





### 3.3.6.1 Storm Drainage Pipes/Culverts

Three storm drainage pipes/culverts have been identified in section 1A for example purposes (see Appendix A, Table 1) all of which cross the HVDC cable system. One at 90°, the other two at approximately 50° and 80°.

If the material used for the drainage pipe or culvert is plastic, polyethylene or concrete, there will be no effect since there can be no induced voltage/current. For the purposes of this report, it has been assumed that these utilities are metallic.

As noted above for crossings at 90° there can be no induction and for other crossing angles the induced voltage varies from a maximum at 0° to zero at 90°.

The Washington County crossings at position 10009 is at an angle of approximately 50° and, as mentioned above has been considered as a parallel utility for simplicity. The induced voltage has been calculated as 11mV. Induced voltages of this level will not have any effect on the service.

The Washington County crossing at 10014+90 is at an angle approaching 90° and therefore the induced voltage has been considered as zero Volts.

### 3.3.6.2 Overhead power cables:

Five National Grid overhead power cable utility services have been identified. Four of which cross the HVDC cable system at varying angles and one runs in parallel.

The actual position of these overhead services relative to the HVDC cable system is not known, therefore a separation distance of 16'5" (5m) has been chosen as approximately representative.

In all instances the induced voltages are very low, the maximum being 15mV. The others being 3, 5 and 6mV respectively.

Induced voltages at this level will have no effect on the services.

### 3.3.6.3 Telecommunications Cables:

Six telecommunication Utility Services have been identified. Four underground and two overhead. The underground services are identified as fiber optic cables, details are not provided for the two overhead services.

The actual positions relative to the HVDC cable system are not known, therefore a separation distance for the underground services of 5' (1520mm) has been assumed, representing the minimum separation distance given in Kiewit drawing C-901 Rev A.

For the overhead services a representative separation of 16'5" (5m) has been taken for the service between 10007+90 and 10009+40 and 19' (5.83m) for the service between 10014+90 and 10038+10 (considering the stated horizontal separation).

For fiber optic cables, there will be no effect on the telecommunication signals since there can be no induced voltage/current, however calculations have been carried out to indicate the induced voltage on any metallic components within the cable (armour for example).

If the telecommunications cable utilizes an open wire (copper) circuit, there is the potential for induced voltage causing interference to the signal.



For the four underground fiber optic services, two cross at 90° and therefore there can be no induced voltage. The induced voltages calculated for the other two are 43mV and 63mV, reflected the length of parallel run. As noted, this induced voltage will have no effect on the telecommunications signals and, being of such low value, will have no effect on connected equipment – assuming the cables contain some metallic component in the construction.

For the two overhead services the calculated induced voltages are 5mV and 59mV. If these services are fiber then, as noted, this induced voltage will have no effect on the telecommunications signals and, being of such low value, will have no effect on connected equipment – assuming the cables contain some metallic component in the construction.

However, if these services are copper then further investigation will be required, following the detailed studies carried out by the converter and cable suppliers, to assess whether there is a problem related to interference with the signals on these services. It is not possible to carry out this assessment at this time.

#### **3.3.6.4 Underground Power Cables, Water or Gas Pipelines:**

No underground power cable, Water or Gas pipeline utilities services have been identified in the area under consideration in this report, that is Package 1A.

If the pipeline material is plastic or polyethylene, there will be no effect since there can be no induced voltage/current.

For information a calculation has been carried out assuming a power cable, or a water or gas pipeline located at the minimum separation distance of 5' (1520mm) which shows the induced voltage will be approximately 463mV/Mile.

#### **3.3.7. Corrosion Effects**

The risk of corrosion of buried metallic utility services is caused by the effects of stray DC currents, and to a lesser extent AC current, flowing in the earth.

For CHPE, the chosen HVDC topology is symmetrical monopole. The DC current in the submarine and underground cables flows in the loop through the positive and negative cables between the two converter stations. There is no path for a DC current outside of this loop, either in normal operation or during faults, thus there can be no DC current flowing in the water or the land under any circumstances.

Stray AC currents would be as a result of induced voltage between the DC cable system and the metallic utility. This is covered in the section above and it can be seen that the levels of induced voltage for all utilities are very low.

Therefore, there will be no corrosion effects on utility services caused by the DC cables.

#### **3.3.8. Transient Fault Conditions**

A fault on the system will result in a short-term disturbance to the steady state (normal) system voltage and current.



In the event of a fault, the current in the DC cable system will rise by a factor of approximately 10 for a period of time of around 100ms, which is the time taken for the main circuit breakers to open and isolate the fault.

During this short time the magnetic fields generated by the DC cable system will rise to a level proportional to the increase in current due to the fault. However, the duration is so short that there will be no effect on utility services.



## APPENDIX A – UTILITIES INTERACTION

**Table 1 – Utilities Interaction**

Utility owner and Location	Utility	Length Parallel (ft)	Parallel /Crossing (°)	Description	Induced Voltage/Comments
Level 3	Fiber Cable in HDPE Duct		C	Fiber Located in RR ROW - East Side	Utility not found, assumed 90° crossing, no induction.
AT&T	Fiber Cable in HDPE Duct		C	Fiber Located in RR ROW - West Side	Utility not found, assumed 90° crossing, no induction.
Washington County 10000+90	Storm Drainage Pipe/Culvert	50	C ≈ 90°	HDP - Route 3	Crossing is at 90°, no induction. Assumes 2' separation (610mm)
National Grid 10004+90	Utility (Electric)	175	C ≈ 60°	Overhead Service Connection - Route 3	5mV - assumes 16'5" separation (5m)
National Grid 10006+05	Utility (Electric)	110	C ≈ 45°	Overhead Service Connection - Route 3	3mV - assumes 16'5" separation (5m). Also parallel for ~200' West Side of Route 3
National Grid 10006+10-10008	Utility (Electric)	200	P	Overhead Lines - Route 3	6mV - assumes 16'5" separation (5m)
National Grid 10007+90	Utility (Electric)	500	C ≈ 25°	Overhead Service Connection - Route 3	15mV - assumes 16'5" separation (5m)
Verizon 10007+90-10009+40	Overhead Telecomm	150	P	Short Aerial Route	5mV - assumes 16'5" separation (5m)
Washington County 10009 – 10000+90	Storm Drainage Pipe/Culvert	63	C ≈ 50°	HDP - Route 3	11mV - assumes 2' separation
Verizon 10009+40-10222+65	Fiber Cable in HDPE Duct	1325	P	Approx. 15' off West edge of pavement - Route 3	43mV - assumes 15' separation (4500mm)



National Grid 10007+85	Utility (Electric)	500	C	Overhead Service Connection - Route 3	15mV - same service as line 14. - assumes 16'5" separation (5m)
Washington County 10014+90	Storm Drainage Pipe/Culvert	50	C $\approx$ 80°	HDP - Route 3	9mV - assumes 2' separation (610mm)
Verizon 10009+75	Fiber Cable in HDPE Duct	1325	P	Approx. 10' off West edge of pavement - Route 3	63mV - assumes 10' separation (3000mm)
Verizon 10014+90 – 10038+10	Overhead Telecomm	2320	P	Approx. 10' off West edge of pavement - Route 3	59mV - assumes 19' separation (5.83m) (3m horizontal, 5m vertical)